

Key Features

- High temperature range: -40°C to +110°C
- Frequency: 13.56 MHz
- Battery supply: 1.5V or 3V
- Data logging from:
 - On-chip temperature sensor
 - External sensor
- ISO 15693 compliant
- Real-time clock for data logging
- Parameter setting via serial bus (SPI)
- 8k bit EEPROM
- Anti-collision capability
- 3-level password authentication

Applications

- Monitoring and tracking of temperature-sensitive products
- Pharmaceutical logistics
- Monitoring of fragile goods transportation
- e-Manifest

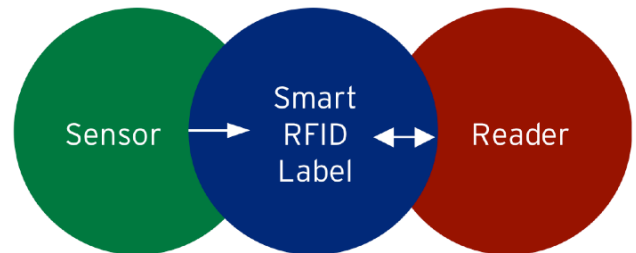

Integrated temperature sensor and RTC!

Description

The IDS-SL13A is a passive/semi-passive tag chip optimized for single-cell, battery-powered smart labels with sensor functionality. The chip is ideal for applications using thin and flexible batteries (1.5V or 3V), but can also be powered from the RF field (electromagnetic waves from an RFID reader/interrogator).

The chip has a fully integrated temperature sensor with a maximum accuracy of 0.5°C. The analogue sensor interface (S_{EXT}) allows the connection of an external sensor. The integrated real-time clock (RTC) is used for time-stamp.

Block Diagram

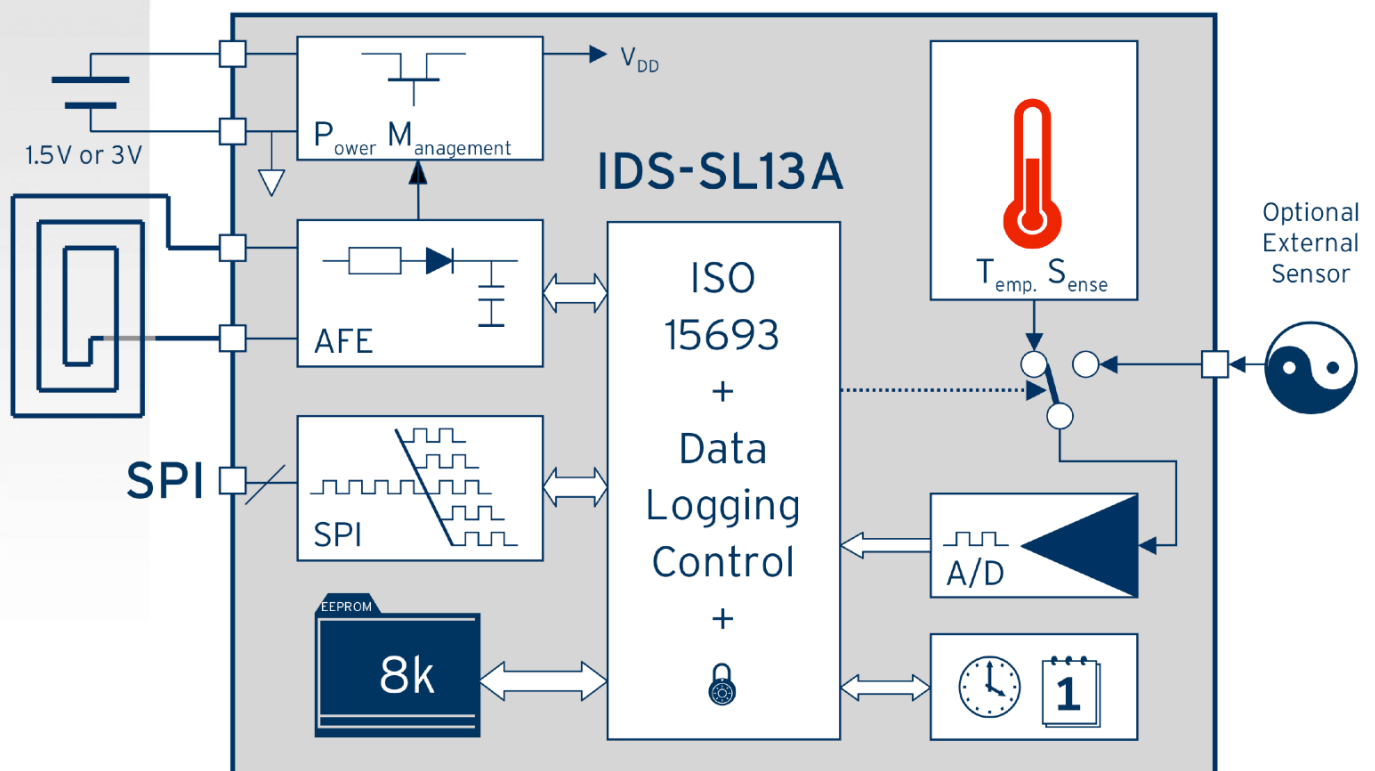

Quick Reference Data

SYMBOL	PARAMETER	CONDITIONS	MIN	TYP	MAX	UNIT
V _{BAT}	Input Battery Supply Voltage	Automatically detects 1.5V or 3V battery and adapts accordingly*	1.1 2.2	1.5 3.0	1.6 3.3	V
I _{DD}	Supply Current	Standby Active (RTC running) Logging mode (20 ms)		2 200	0.1	μA
F	Frequency Band		13.553	13.56	13.567	MHz
T _A	Operating Ambient Temperature		-40		110	°C
T _{S-R}	Temperature Sensor Range	Nominal range With reduced integral non-linearity	-20 -80		60 80	°C
T _{S-A}	Temperature Sensor Accuracy				+/-0.5	°C
T _{RTC-I}	Real-Time Clock, Interval	Programmable	2		32,768	sec
T _{RTC-A}	Real-Time Clock, Accuracy				+/-3	%

*) The chip automatically detects whether a 1.5V or a 3V battery is connected and adapts accordingly for optimal performance.

Smart Passive/Semi-Passive Label

The IDS-SL13A is designed for use in smart passive and semi-passive labels. Smart RFID labels are defined as thin and flexible labels that contain an integrated circuit and a power source. SAL includes in its definition semi-passive smart labels, also known as battery-assisted back-scattered passive labels, which enable enhanced functionality and superior performance over existing passive labels. The IC includes sensor functionality and logging of sensor data.

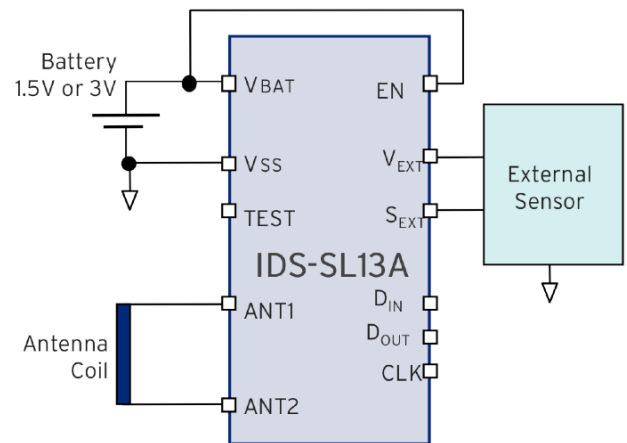

Typical application with external sensor

Delivery Form

The IDS-SL13A will be available in a 12-pin QFN or as tested wafers (8"). Inlays and labels are available through our partners.

Sales & Marketing EMEA

IDS Microchip AG
 Wächlenstrasse 5,
 CH-8832 Wollerau, Switzerland
 Phone: +41 43 844 6253
 Fax: +41 55 462 1103
 sales@ids-microchip.com

Sales & Marketing Americas & Asia

IC Magic Inc.
 34 Granlea Rd,
 North York, ON M2N 2Z5, Canada
 Phone: +416 227 9196
 Fax: +41 55 462 1103
 sales@ic-magic.com

www.ids-microchip.com

Product Flyer is product information in short form. Characteristic data and other specifications are preliminary. IDS reserves the right to change or discontinue such products without notice. The information furnished here by IDS is believed to be correct and accurate as of the publication date. However, IDS shall not be liable to any third party for any damages, including but not limited to personal injury, property damage, loss of profits, loss of use, interruption of business or indirect, special, incidental, or consequential damages of any kind in connection with or arising out of the furnishing, performance, or use of the technical data. No obligation or liability to any third party shall arise or flow out of IDS' rendering technical or other services.