



IDS

IDS-R13MP

13.56 MHz RFID Reader

Multi-Protocol Including ISO 14443, ISO 15693 and Cool-Log™

Protocols:

- ISO/IEC 15693
- ISO 14443A/B
- Cool-Log™
- Tag-it™, FeliCa

Key Features

- Supply voltage range: 2.7V to 5.5V
- Selectable protocols
- Antenna driver using OOK or ASK modulation
- Dual receiver input providing both AM and PM demodulation eliminating communication holes
- Reception automatic gain control
- On-chip voltage regulator providing up to 20mA for external MCU
- Reader-to-reader anti-collision
- Power-down, standby and active mode
- Temperature range: -40°C to 110°C

Package

- 32-pin QFN

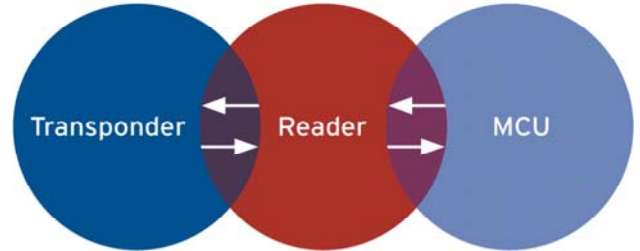

Description

The IDS-R13MP is an integrated analogue front end and data framing system for 13.56MHz RFID systems. The built-in programming options make it suitable for a wide range of applications both in proximity and vicinity RFID systems.

The reader configuration is achieved by selecting the desired protocol in the control registers. The direct access to all control registers also allows fine-tuning of different reader parameters if required.

Applications

- 13.56 MHz RFID reader systems

Block Diagram

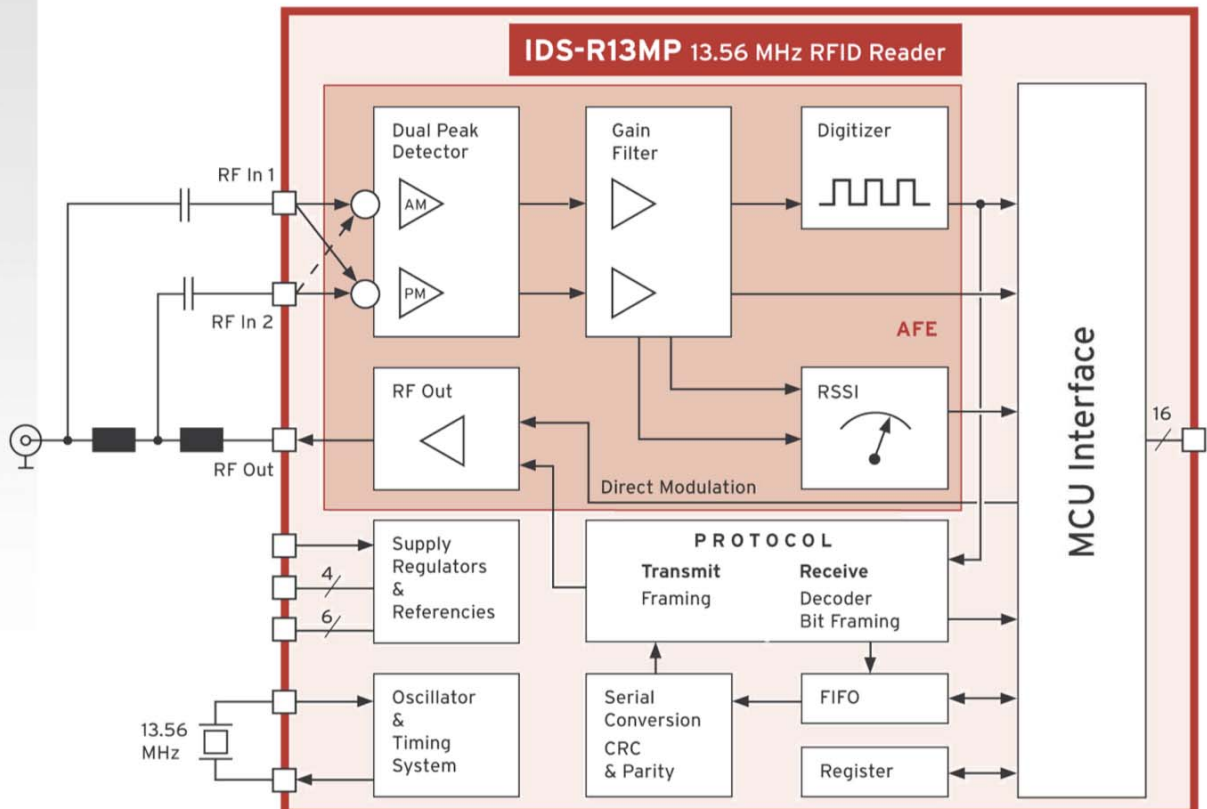

FEATURE	BENEFITS	REMARKS
AFE, bit coding/decoding, data framing, CRC checking, supply regulators, MCU support functions	Few external components and hence low BOM No need for dedicated CPU	It's all there!
Multi-protocol	One reader for all tags	Direct mode for proprietary protocols
Wide temperature range: -40°C to 110°C	Enables usage in harsh environments	
Dual AM/PM reception	Eliminating communication holes Secure and yet fast reading	RSSI detection for both AM and PM ensuring PM reception is selected only when needed
Reception AGC and AGL	High level of robustness Institute correct reception from multiple tags in various distances	The AGC settings are accessible through the register
User-accessible registers	Allows configuration of various options and fine-tuning of parameters	Programmable via MCU interface
MCU interface	Allows "off-line" operation of external low-cost 8-bit MCU (no real-time operation needed)	Parallel or serial (SPI)
Adaptive supply regulator system	Automatically adopts to the external supply and hence assures high PSRR and prevents interference	Patent pending Settings are accessible through the register
Low power consumption	Suitable for handheld devices	Works from a battery

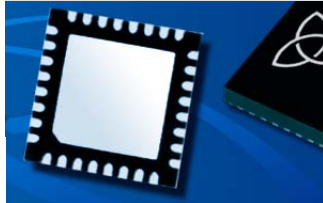
HIGHLY INTEGRATED	TINY FORM FACTOR
✓ Integrated AFE with AM/PM and AGC/AGL reception	
✓ Integrated 100/200 mW power amplifier	
✓ Integrated low level bit coding and decoding	
✓ Integrated data framing	
✓ Integrated CRC checking	
✓ Integrated supply regulators	
✓ Integrated MCU support functions	
	32-pin QFN
	5 x 5 mm
	RoHS compliant • Pb-free

Sales & Marketing EMEA
 IDS Microchip AG
 Wächlenstrasse 5,
 CH-8832 Wollerau, Switzerland
 Phone: +41 43 844 6253
 Fax: +41 43 844 6250
 sales@ids-microchip.com

Sales & Marketing Americas & Asia
 IC Magic Inc.
 34 Granlea Rd,
 North York, ON M2N 2Z5, Canada
 Phone: +416 227 9196
 Fax: +41 43 844 6250
 sales@ic-magic.com

www.ids-microchip.com

Product Flyer is product information in formative and short form. Characteristic data and other specifications are typical values. IDS Microchip reserves the right to change or discontinue such products without notice. The information furnished here by IDS is believed to be correct and accurate as of the publication date. However, IDS shall not be liable to any third party for any damages, including but not limited to personal injury, property damage, loss of profits, loss of use, interruption of business or indirect, special, incidental, or consequential damages of any kind in connection with or arising out of the furnishing, performance, or use of the technical data. No obligation or liability to any third party shall arise or flow out of IDS' rendering technical or other services.

Cool-Log™ is a registered trademark of IDS Microchip AG.

Tag-it™ is a registered trademark of Texas Instruments, Inc.