

Conductive Plastic Angle Sensor

**CP-2FABSJ Series**

- Conductive Plastic Angle Sensor
- Effective Electrical Travel : 90°
- Independent Linearity : ±3%
- with Return Spring
- IP 65

**【Material】**

- Housing : PBT
- Shaft : Stainless Steel
- Bearing : Copper Alloy

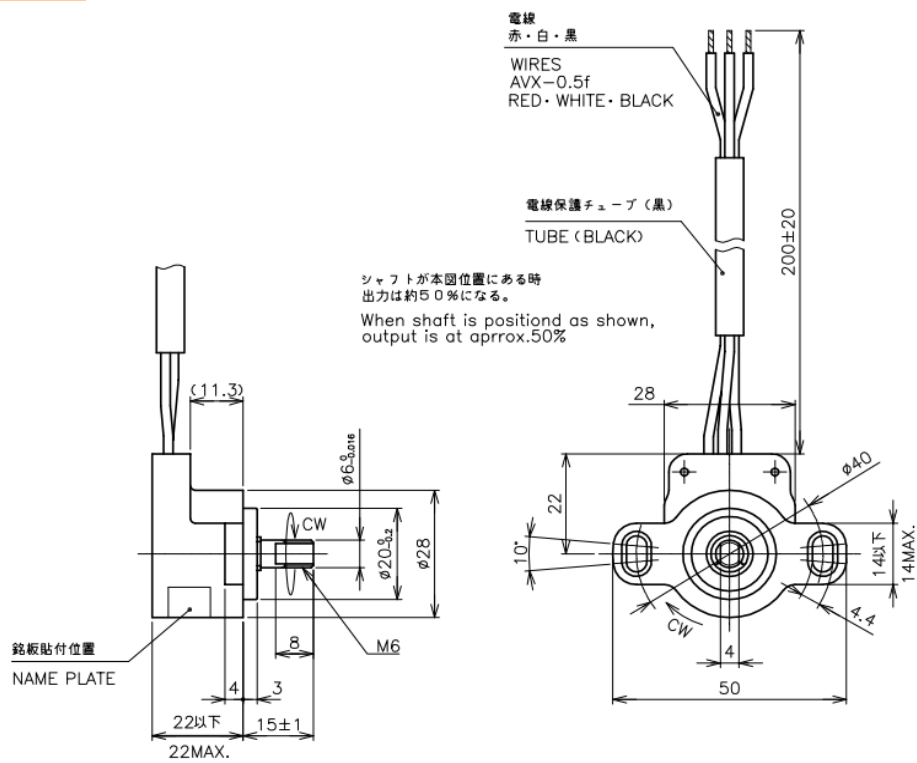
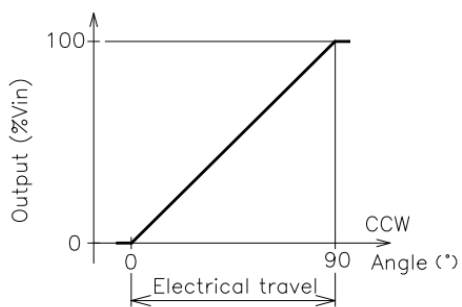
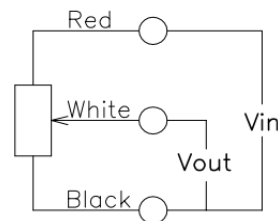
**Dimension** [mm]**Output Characteristics****Schematic**

- Red, White, Black indicate wire colors.

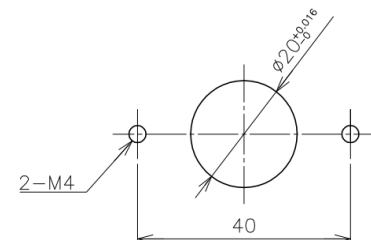
**Mounting**

<b>【Model No.】</b>	CP-2FABSJ
--------------------	-----------

**【Electrical Specifications】**

Effective Electrical Angle	90 ±3	°
Total Resistance	1	kΩ
Total Resistance Tolerance	±20	%
Independent Linearity	±3	%
Max. Input Voltage	DC18/50°C	W
Insulation Resistance	MIN. 100/DC1000V	MΩ
Dielectric Strength	AC1000/1Minute	V
Temperature Coefficient Of Resistance	±400	ppm/K

**【Mechanical Specifications】**

Total Mechanical Travel	100 ±5	°
Torque	20~100	mN·m
Stopper Strength	MIN. 1	N·m
Thrust Load Tolerance	3	N
Radial Load Tolerance	4	N
Mass	Approx. 35	g

**【Environmental Specifications】**

Life Cycles	5 Million	Cycle
Category Temperature Range	-40~+100	°C
Storage Temperature Range	-40~+100	°C
Vibration	245m/s <sup>2</sup> 20~500Hz 3axis 2hours each	
Shock	500m/s <sup>2</sup> 11ms 3axis 6directions 3times	
IP Level	IP65	

**■ Options**

- Without return spring
- Dual Output (Effective Electrical Angle: up to 90°)
- Total resistance: 1k~5kΩ on request
- Other effective electrical travel :   Single Output - up to 340°  
  Dual Output - up to 90°

**■ Handling Instruction**

- To avoid burnout of resistive element, do not supply more than 1mA current to terminal white.
- Miswiring might cause burnout of resistive element.
- To reduce sliding noise, add load resistance should be more than 100times and less than 1000times of total resistance.
- Slight continuous vibration such as dither might cause short lifetime of the sensor.