



TW150 L-Band/GNSS 1 to 2 Signal Splitter

The TW150 by Tallysman Wireless is a professional grade 1 to 2 L-Band Signal Splitter, suitable for a wide range of L-Band and all GNSS applications, including GPS L1, L2, L5 and GLONASS L1 & L2. The TW150 splitter permits for two GNSS receivers to operate on one antenna, by allowing the DC voltage source to pass through Port 2 but blocked on Port 1.

The TW150 is housed in a robust weatherproof (IP67) clear anodized aluminum enclosure and is available with 3 x gold-plated SMA or TNC Jack (female) connectors.

Applications

- L-Band Signal Distribution
- GPS L1, L2 & L5 Signal Distribution
- GLONASS L1 & L2 Signal Distribution
- Galileo E1, E5 & E6 Signal Distribution

Features

- 1 to 2 GHz operating frequency
- Low insertion loss 1.0 dB @ 2 GHz
- VSWR <1.25 typ.
- Max pass through current 200 mA
- 50 Ohm port impedance
- Clear anodized aluminum, IP67 housing
- Gold-plated SMA or TNC Jack connectors
- RoHS Compliant

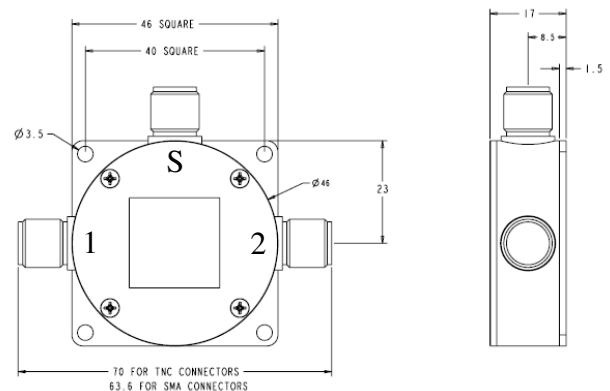
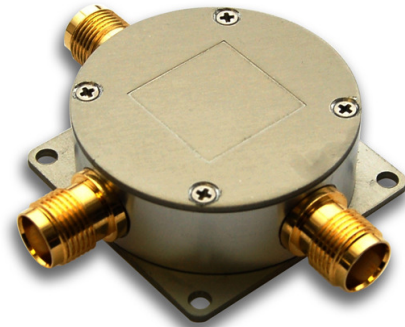

Benefits

- Compact form factor
- Allows use of two GNSS receivers on one antenna
- Fits in line with antenna cable
- Robust design
- Suitable for harsh environments



TW150 L-Band/GNSS 1 to 2 Signal Splitter

Specifications

Electrical

• Operational Frequency	1 to 2 GHz
• VSWR (50Ω)	1.25 typ., 1.5 max
• Insertion Loss	<1.6 dB @ 2 GHz
• Max Input Power	1.5 W
• Max Pass Through Current	200 mA
• Supply Voltage	18 VDC max
• High Port Isolation	>18 dB
• Amplitude Balance	0.5 dB max
• Phase Balance	2 degrees typ.

Mechanicals

• Size	1.81" L x 1.81"W x 0.669" H (46 mm L x 46 mm W x 17 mm H)
• Weight	100 g (0.22 lbs)
• Connectors	3 x SMA or 3 x TNC Jack
• Operating Temp. Range	-40 to +85 C
• Enclosure	Clear anodized aluminum, IP67 compliant
• Environmental	RoHS complaint
• Warranty	One year – parts and Labour

Ordering Information

• TW150 – 1 to 2 L-Band/GNSS Splitter with SMA jacks	32-0150-0 *
• TW150 – 1 to 2 L-Band/GNSS Splitter with TNC jacks	32-0150-1 *

* "25mA DC load (DCL) option on port 1" can be provided if required by receiver

Please contact Tallysman Wireless for additional information

Tallysman Wireless Inc

106 Schneider Road, Unit 3
Ottawa ON K2K 1Y2 Canada
Tel 613 591 3131
Fax 613 591 3121
sales@tallysman.com

The information provided herein is intended as a guide only and is subject to change without notice. This document is not to be regarded as a guarantee of performance. Tallysman Wireless Inc. hereby disclaims any or all warranties and liabilities of any kind. © 2011 Tallysman Wireless Inc. All rights reserved.