

ULTRA-HIGH PERFORMANCE INERTIAL MEASUREMENT UNIT (IMU)



STIM300

PRODUCT BRIEF

- Small size, low weight and low cost
- ITAR free
- Insensitive to magnetic fields
- 0.5°/h gyro bias instability
- 0.15°/√h angular random walk
- ±400°/s angular rate input range
- 10°/h gyro bias error over temperature gradients
- 0.05mg accelerometer bias instability
- ±10g acceleration input range (optional ranges avail.)
- 3 inclinometers for accurate levelling
- Auxiliary input

STIM300 is a high performance and rugged Inertial Measurement Unit (IMU) comprised of 3 highly accurate MEMS gyros, 3 high stability accelerometers and 3 inclinometers. The IMU is factory calibrated and compensated for temperature effects over the full temperature operating range.

The STIM300 is based upon Sensoror's proven gyro sensor technology in production for more than a decade, and its high precision Gyro Modules are already designed into many applications worldwide. Another advantage of the Sensoror MEMS technology is the very low vibration and shock sensitivity in any direction.

Range and features

STIM300 full-scale angular rate input range is ±400°/s and the output is capped at ±480°/s. Standard acceleration input range is ±10g. Axis misalignment of as little as 1mrad is achieved by electronic axis alignment. STIM300 requires a single +5Vdc power supply and has a digital serial RS422 interface.

STIM300 offers several user selectable output formats and sample rates for gyro and accelerometer data:

- Angular Rate
- Incremental Angle
- Average Angular Rate
- Integrated Angle
- Acceleration
- Incremental Velocity
- Average Acceleration

Device configurations and self-diagnostics

A reliable RISC ARM microcontroller enables easy device configuration and programming. The user selectable Service Mode allows for setting the output unit format, sample frequency, LP filter cut-off frequency, RS422 transmission bit rate and line termination. Service Mode also enables single measurements on demand, and to access detailed diagnostics information.



(39mm x 45mm x 22mm)

Evaluation tools

STIM300 evaluation tools supporting PCI or USB connectivity are available. The evaluation tools offer easy access to measurement data and configuration of the IMU. It supports data sampling at alternative rates, graphical presentation, and data logging to file. The evaluation tools contain a RS422 interface for USB or PCI hardware setup, all necessary cabling, and PC software.

Application areas

The STIM300 IMU is well suited for stabilization, guidance and navigation applications in Industrial, Aerospace and Defense markets. It is a crucial building block for inertial navigation systems in UAVs, AUVs, AGVs, UGVs and ROVs, missiles, robotics, and more, and offers the designer an ITAR free alternative. In many applications, STIM300 can competitively replace IMU's based on Fiber Optic Gyros (FOGs) and improve system performance with respect to robustness, reliability, size, weight, power and cost.

SPECIFICATIONS

Parameter	Min	Nom	Max	Unit
GENERAL				
Weight		55		g
Operating temperature	-40		85	°C
Supply voltage	4.5	5.0	5.5	V
Supply current		300		mA
Start-up time			1	s
Sample rate			2000	SPS
Mechanical shock, any direction			1500	g
RS422 transmission bit rate			1.84	Mbit/s
Misalignment		1		mrad
GYRO				
Input range		±400 ¹⁾		°/s
Resolution		0.22		°/h
Bias instability		0.5		°/h
Angular random walk		0.15		°/√h
Bias error over temperature gradients		±10 ²⁾		°/h rms
Scale factor accuracy		±500		ppm
ACCELEROMETER				
Input range		±10 ³⁾		g
Resolution		1.9		µg
Bias instability		0.05		mg
Velocity random walk		0.06		m/s/√h
Bias error over temperature gradients		±2 ²⁾		mg rms
Scale factor accuracy		±300		ppm
INCLINOMETER				
Input range		±1.7		g
Resolution		0.2		µg
Scale factor accuracy		±500		ppm

1) Optional ranges are available
 2) Condition: ΔT ≤ 1°C/min
 3) Optional ranges: ±5g, ±30g, ±80g

MECHANICAL DIMENSIONS

All dimensions in mm.

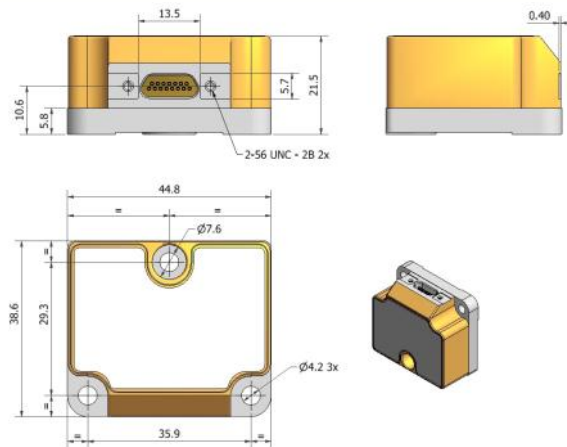

Volume < 2,0 cu. in (33cm³)

ELECTRICAL CONNECTIONS

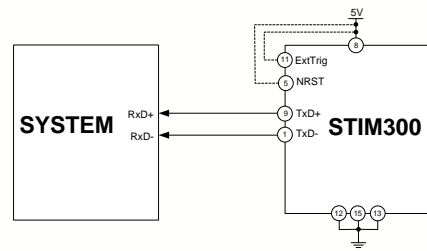

(TRANSMIT ONLY)

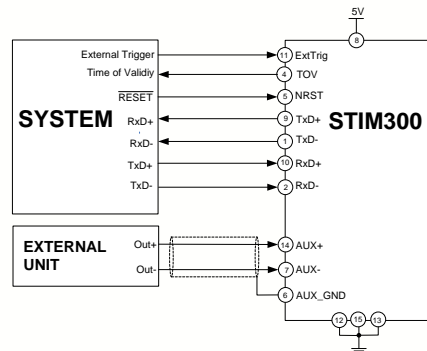

(FULL FUNCTION)

FUNCTIONAL BLOCK DIAGRAM

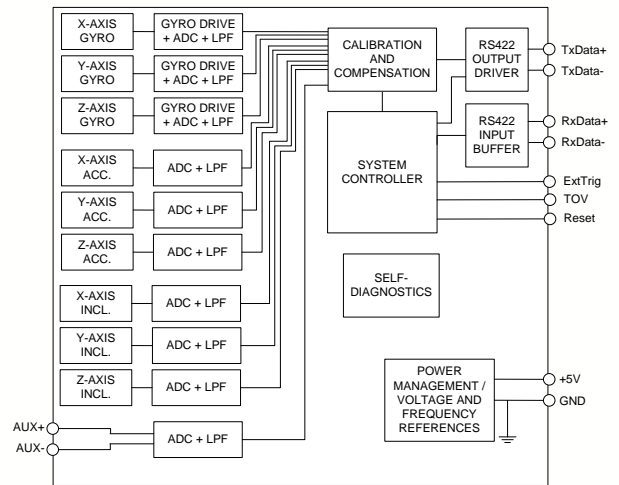

PIN OUT

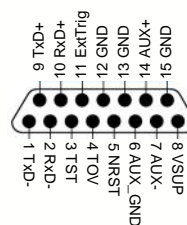

AXIS DEFINITIONS

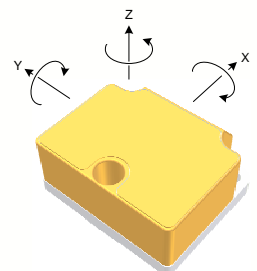

Information furnished by Sensoror is believed to be accurate and reliable. However, no responsibility is assumed by Sensoror for its use, nor for any infringements of patents or other rights of third parties that may result from its use. Sensoror reserves the right to make changes without further notice to any products herein. Sensoror makes no warranty, representation or guarantee regarding the suitability of its products for any particular purpose, nor does Sensoror assume any liability arising out of the application or use of any product or circuit, and specifically disclaims any and all liability, including without limitation consequential or incidental damages. No license is granted by implication or otherwise under any patent or patent rights of Sensoror. Trademarks and registered trademarks are the property of their respective owners. Sensoror products are not intended for any application in which the failure of the Sensoror product could create a situation where personal injury or death may occur. Should Buyer purchase or use Sensoror Technologies products for any such unintended or unauthorized application, Buyer shall indemnify and hold Sensoror Technologies and its officers, employees, subsidiaries, affiliates, and distributors harmless against all claims, costs, damages, and expenses, and reasonable legal fees arising out of, directly or indirectly, any claim of personal injury or death associated with such unintended or unauthorized use, even if such claim alleges that Sensoror Technologies was negligent regarding the design or manufacture of the part.