



A Tallysman *Accutenna*® TW2643POC Magnet Mount Passive Iridium® / GNSS Antenna for Open Cellular Design

The TW2643POC is the antenna specified by Open Cellular and is shown on the third page of this document. This Antenna includes all parts as shown on Page 3. No additional parts need to be ordered.

The TW2643POC employs Tallysman's unique *Accutenna* technology in a magnet mount, passive right hand circularly polarised antenna for the reception of all of the GNSS constellations (GPS L1/GLONASS G1/ Galileo E1/ BeiDou B1) plus Iridium: 1559 to 1626.5 MHz frequency band. It is certified and specially designed to maximize the performance of Iridium™ Voice and Data Modems plus the upper GNSS band (1559 – 1606MHz)

The TW2643POC features a high performance dual-feed patch element that provides great axial ratio (4.5dB max, <1.5dB @ zenith) over the entire Iridium™ + upper GNSS frequency band, thus signals at the band edges remain truly circular, unlike the response of single feed antennas.

The TW2643POC is housed in a compact, industrial-grade weather-proof, magnet mount enclosure, with threaded base holes for screw down attachment.



Applications

- Iridium™ Voice and Data Applications+ GNSS
Specifically for the Open Cellular Specification

Features

- Custom high gain, 5dBic dual-feed patch
- Great axial ratio, <1.5dB over full bandwidth
- 15 KV ESD circuit protection
- IP67 weather proof housing
- Robust Industrial grade enclosure
- Magnet or screw mount

Benefits

- Excellent circular polarized signal transmission
- Industrial temperature range
- Rugged Design
- Ideal for harsh environments
- RoHS compliant



TW2643POC Magnet Mount Passive Iridium® / GNSS Antenna for Open Cellular Design

Specifications Vcc = 3V, over full bandwidth, T=25°C

Antenna

Architecture	Dual, quadrature feeds			
Antenna Gain (dBic, 100mm ground plane)	B1/E1	L1	G1	Iridium
	>3.5	>4.5	>5	>4.5
Axial Ratio (over full bandwidth)	≤1.5 dB			

Electrical

Frequency Bandwidth	1559 to 1626.5 MHz
Polarization	RHCP
Cross Polarization Rejection	typically 20dB
VSWR (at antenna)	<1.5:1 typ 1.8:1 max.
ESD Circuit protection	15 KV air discharge

Mechanicals & Environmental

Mechanical Size	57 mm dia. x 15 mm H
Cable	RG174 / 50 cm, custom lengths optional
Operating Temp. Range	-40 to +85 °C
Enclosure	Radome: ASA plastic, Base: Zamak white metal
Weight	160 g
Attachment Method	Magnet or permanent (pre-tapped 4 x 6-32UNC)
Environmental	IP67 and RoHS compliant
Shock	Vertical axis: 50 G, other axes: 30 G
Vibration	3 axis, sweep = 15 min, 10 to 200 Hz sweep: 3 G

Ordering Information

TW2643POC – Passive Iridium™ + GNSS antenna, 33-2643POC-yyyy
Where yyyy = cable length in mm

Please refer to the Ordering Guide (<http://www.tallysman.com/wp-content/uploads/Current-Ordering-Guide.pdf>) for the current and complete list of available connectors.

Tallysman Wireless Inc

36 Steacie Drive
Ottawa ON K2K 2A9 Canada
Tel +1 613 591 3131 Fax 613 591 3121 sales@tallysman.com

The information provided herein is intended as a guide only and is subject to change without notice. This document is not to be regarded as a guarantee of performance. Tallysman Wireless Inc. hereby disclaims any or all warranties and liabilities of any kind. © 2017 Tallysman Wireless Inc. All rights reserved. Rev 1.

1

2

3

4



CRITICAL DIMENSION

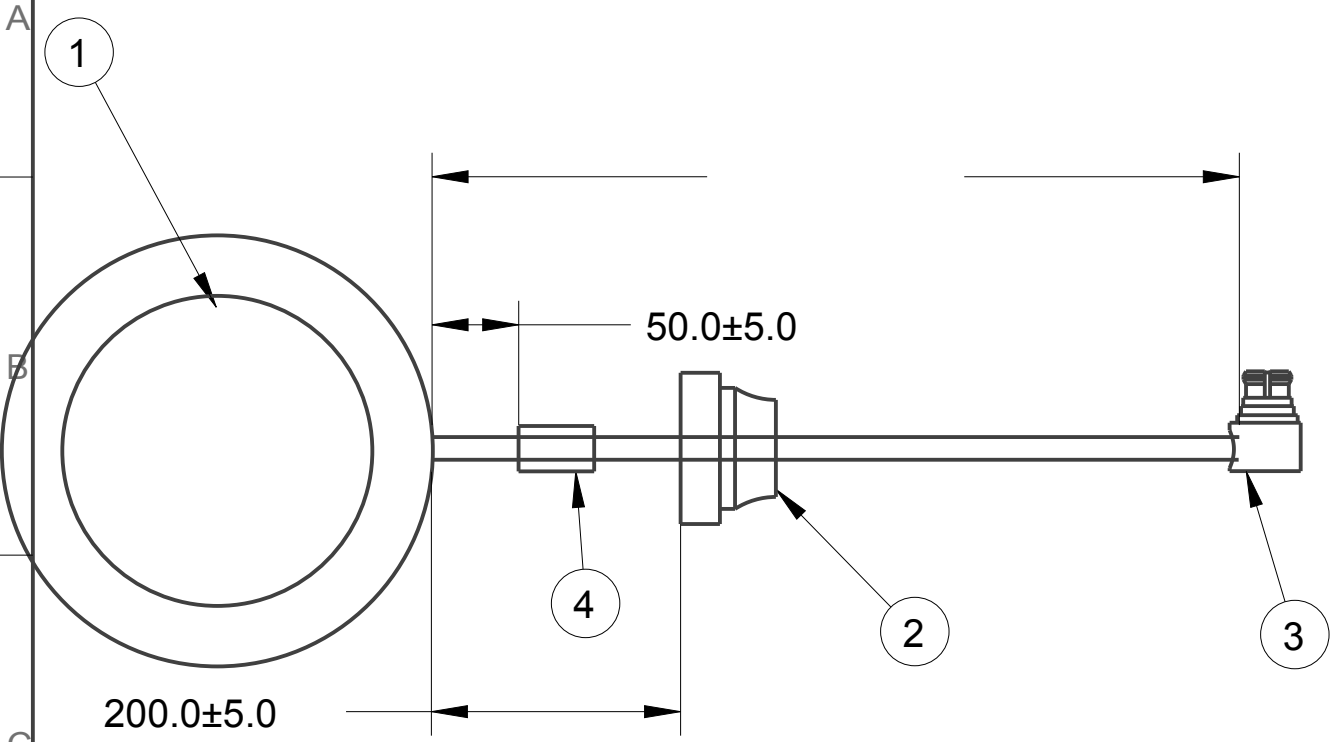

Reference details for wiring and marking

Notes

- 1. This assembly must have material compliance recognized by UL
- 2. Contact & Connector housing must be from the same manufacturer
- 3. Stripping & Crimping instructions, use qualified connector Manufacturer individual instructions
- 4. Grommet to be assembled before assembling the connector to cable

S.No	Open Cellular Part #	Manufacturer Part #	Description	Manufacturer	Quantity
1	227-001386	TW2643POC	Waterproof Passive GPS Antenna, OpenCellular, TIP	TALLYSMAN	1
2			Grommet		1
3			SMP Right Angle Connector		1
4		-	Marking Tube		1

02

FINISH SPECIFICATION



1

2

3

4