



## TW3010/TW3012 Permanent Mount GPS L1 Antenna

The TW3010/TW3012 by Tallysman is a professional grade, permanent mount GPS L1 antenna, specially designed for precision tracking and timing applications.

The TW3010/TW3012 features a custom high performance, wide band patch element, a 30dB gain LNA stage and a high rejection out-of-band SAW filter. The TW3012 includes a tight SAW pre-filter to provide strong protection against out-of-band signals. It provides  $\pm 10$ MHz bandwidth centred on 1575.42 MHz and covers the GPS L1, and SBAS (WAAS/EGNOS/MSAS) signals. It provides great axial ratio, excellent circular polarized signal reception, great multipath rejection and great out-of-band signal rejection.

The TW3010/TW3012 is housed in a permanent mount industrial-grade weather-proof enclosure. Optional Mounts of an L Bracket (PN 23-0040-0) or Pipe Mounts (PN 23-0065-0) are available.

### Applications

- Mission Critical GPS Tracking & Timing
- Precision Agriculture, Mining & Construction
- Military & Security
- Avionics
- Law Enforcement & Public Safety
- Fleet Management & Asset Tracking



TW3010/TW3012 Dimensions (mm)  
Conical Radome shown. Flat Radome also available

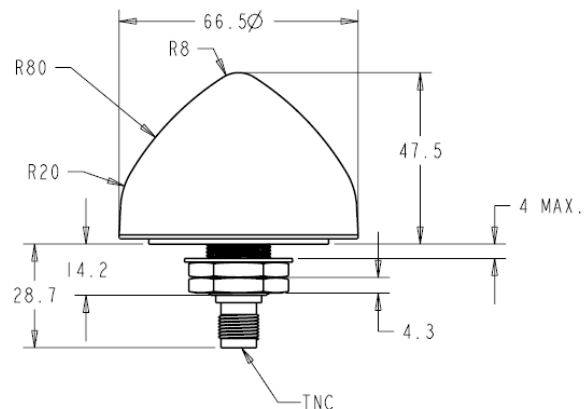

### Features

- Great axial ratio
- Low noise LNA: <4 dB
- High rejection SAW filter
- High gain: 28 dB typ.
- Low current: 9 mA typ
- ESD circuit protection: 15 KV
- Wide supply voltage range: +2.5 to 16 VDC
- Weather proof housing: IP67

### Benefits

- Excellent multipath rejection
- Increase system accuracy
- Excellent signal to noise ratio
- Great out of band signal rejection
- Ideal for harsh environments
- RoHS and REACH compliant



# TW3010/TW3012 Permanent Mount GPS L1 Antenna

## Specifications Vcc = 3V, over full bandwidth, T=25°C

### Antenna

Antenna Element Gain (100mm ground plane)	>4 dBic at 90°
Axial Ratio (over full bandwidth)	≤4 dB typ. 5 dB max.

### Electrical

Architecture	2 stage LNA circuit + a mid section SAW filter.	
Frequency Bandwidth	1575 MHz ± 10 MHz	
Polarization	RHCP	
Gain	26 dB min, 28 dB typ.(TW3010) 24dB min (TW3012)	
Out-of-Band Rejection	<1560 MHz	TW3010 >42 dB
	>1600 MHz	TW3012 >65 dB
	>1620 MHz	TW3012 >50 dB
VSWR (at LNA input)	<1.5:1 typ. 1.8:1 max	>70 dB
Noise Figure	1 dB typ. (TW3010) <4 dB typ. (TW3012)	
Supply Voltage Range	+2.5 to 16 VDC nominal (12VDC recommended maximum)	
Supply Current	9 mA (typ) across all input voltages	
ESD Circuit Protection	15 KV air discharge	

### Mechanicals & Environmental

Mechanical Size	66.5 mm dia. x 21 mm H
Operating Temp. Range	-40 to +85 °C
Enclosure	Radome: EXL 9330, Base: Zamak White Metal
Weight	150 g
Attachment Method	19mm surface or bracket mount, L-Bracket and Pipe Mount available
Environmental	IP67, REACH, RED, and RoHS compliant
Shock	Vertical axis: 50 G, other axes: 30 G
Vibration	3 axis, sweep = 15 min, 10 to 200 Hz sweep: 3 G
Salt fog / spray	MIL_STD-810F Section 509.4
Warranty	One year – parts and labour

### Ordering Information

TW3010 – GPS L1 antenna 33-3010-xx-yy-zzzz TW3012 – GPS L1 Antenna w/pre-filter 33-3012-xx-yy-zzzz  
 Where xx = connector type, yy = radome type and colour and zzzz = cable length (where applicable)

Please refer to the Ordering Guide (<http://www.tallysman.com/wp-content/uploads/Current-Ordering-Guide.pdf>) for the current and complete list of available radomes and connectors.



An ISO 9001:2015  
 Certified Company

36 Steacie Drive, Ottawa ON K2K 2A9 Canada

Tel 613 591 3131

Fax 613 591 3121

[sales@tallysman.com](mailto:sales@tallysman.com)

The information provided herein is intended as a guide only and is subject to change without notice. This document is not to be regarded as a guarantee of performance. Tallysman Wireless Inc. hereby disclaims any or all warranties and liabilities of any kind. © 2010 Tallysman Wireless Inc. All rights reserved. Rev 6.8