



TW3350/TW3352 Wideband GPS/GLONASS Antenna

The TW3350/TW3352 is a high performance antenna covering the GPS L1, GLONASS L1 and SBAS (WAAS, EGNOS & MSAS) frequency band (1575 to 1606 MHz). It features a patch element with 40% wider bandwidth than hitherto available in this format. Unlike its competitors, both GPS-L1 and GLONASS signals are included in the 1dB received power bandwidth.

The TW3350/TW3352 has a two stage Low Noise Amplifier with a mid-section SAW. An optional tight pre-filter is available with part number TW3352 to protect against saturation by high level sub-harmonics and L-Band signals.

The TW3350/TW3352 has a 19mm (3/4 Inch) through-hole mount white metal base, specifically designed for mobile installations, with an industrial-grade, IP67 compliant conical radome. Two options for pole mounting are available an L-bracket (P/N#23-0040-0) or a pipe mount (P/N#23-0065-0).

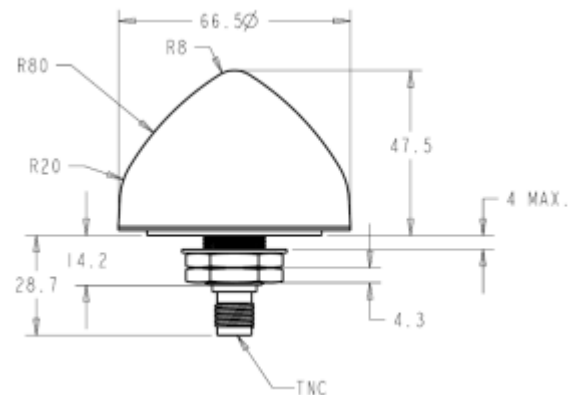

Applications

- Cost Sensitive Mission Critical Positioning
- Military & Security
- Fleet Management & Asset Tracking

Features

- Low noise LNA: 1 dB typical (TW3350)
- High rejection mid-section SAW filter
- Available Pre-filter (TW3352)
- High gain: 28 dB typ.
- Wide voltage input range: 2.5 to 16 VDC
- IP67 weather proof housing
- Low Power: 9mA typ. at 2.3Vcc min.

Benefits

- Bandwidth fully Includes GPS-L1 & GLONASS
- Excellent multipath rejection
- Increased system accuracy
- Excellent signal to noise ratio
- Great out of band signal rejection
- Ideal for harsh environments
- RoHS and REACH compliant



TW3350/TW3352 Wideband GPS/GLONASS Antenna Specifications

Antenna

Architecture	Wideband Single Feed Patch
1 dB Bandwidth	31 MHz
10dB Return Loss Bandwidth	45MHz
Antenna Gain (with 100mm ground plane)	4.5 dBic
Axial Ratio	<4dB @ 1590MHz, 8 dB typical at band edges

Electrical

Architecture	TW3350	LNA stage 1 -> SAW filter-> LNA stage 2
	TW3352	SAW Pre-filter ->LNA stage 1 -> SAW filter-> LNA stage 2
Filtered LNA Frequency Bandwidth		1574 to 1606 MHz
Polarization		RHCP
Gain (1575.42 to 1606 MHz)		28dB min., TW3350; 26dB, TW3352,
Gain flatness		+/- 2 dB, 1575 to 1606 MHz
Out-of-Band Rejection		<1500 MHz >35 dB (TW3350)
		<1550 MHz >25 dB (TW3350)
		>1640 MHz >35 dB (TW3350)
VSWR (at LNA output)		<1.5:1 typ. 1.8:1 max.
Noise Figure		1 dB typ., TW3350; 2.5dB typ., TW3352
Supply Voltage Range (over coaxial cable)		+2.5 to 16 VDC nominal (12VDC recommended maximum)
Supply Current		10 mA max.
ESD Circuit Protection		15 KV air discharge

Mechanicals & Environmental

Mechanical Size	66.5 mm dia. x 21 mm H
Cable (Option)	Custom flying cable assembly available.
Operating Temperature Range	-40 to +85 °C
Enclosure	Radome: EXL9330, Base: Zamak White Metal
Weight	150 g
Environmental	IP67, REACH, RED, and RoHS compliant
Shock	Vertical axis: 50 G, other axes: 30 G
Vibration	3 axis, sweep = 15 min, 10 to 200 Hz sweep: 3 G
Salt Spray	MIL-STD-810F Section 509.4

Ordering Information

Part Numbers:

TW3320 – GPS/GLONASS antenna	33-3320-xx-yy-zzzz
TW3322 – GPS/GLONASS antenna w/pre-filter	33-3322-xx-yy-zzzz
Where xx = connector type, yy = type and colour of radome, and zzzz = cable length in mm (where applicable)	

Please refer to the Ordering Guide (<http://www.tallysman.com/orderingguide.php>) for the current and complete list of available radomes and connectors.



36 Steacie Drive, Ottawa ON K2K 2A9 Canada

Tel +1 613 591 3131 Fax 613 591 3121 sales@tallysman.com

The information provided herein is intended as a guide only and is subject to change without notice. This document is not to be regarded as a guarantee of performance. Tallysman Wireless Inc. hereby disclaims any or all warranties and liabilities of any kind. © 2010 Tallysman Wireless Inc. All rights reserved.

Rev 3.3