

FECS41-250 - for the Detection of Nitric Oxide

Features:

- * High sensitivity/selectivity to NO
- * Quick response to NO
- * Linear output
- * Long life
- * Stable baseline
- * Unique leak-proof structure

Applications:

- * Portable and fixed installation NO monitors
- * NO detectors
- * Ventilation control for indoor parking garages

Figaro's Nitric Oxide Sensor FECS41-250 is a unique electrochemical-type nitric oxide sensor. Its most notable feature is its unique leak-proof structure, making it ideal for NO monitors and detectors in various fields.



Sensitivity Characteristics:

Typical characteristics (linearity) of FECS41-250 (20°C) are shown below.

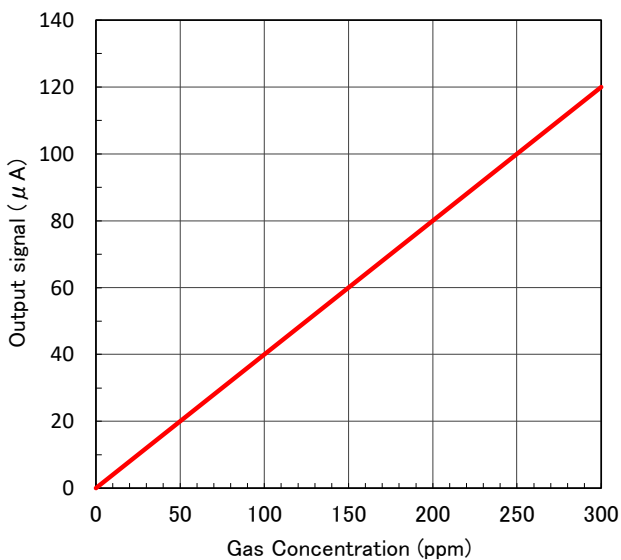

Temperature Dependency:

Typical characteristics (temperature dependency) of FECS41-250 are shown below.

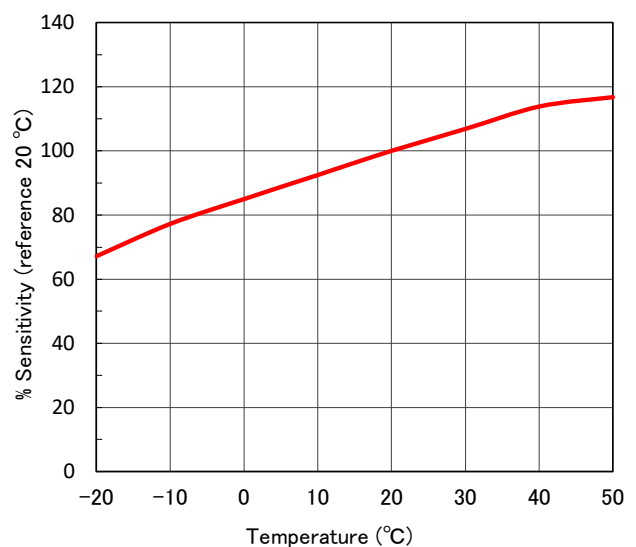

Specifications:

Detection Gas	Nitric Oxide
Detection Range	0 ~ 300 ppm
Maximum Overload	1000 ppm
Output Signal	400 ± 80 nA/ppm (*)
Repeatability	±2% (*)
Resolution	0.5 ppm (*)
Typical Baseline Range (Pure air)	< 3 ppm (*)
Typical Response Time (t ₉₀)	< 40 seconds (*)
Typical Baseline Shift (-20 ~ 40°C)	< 4 ppm(*)
Long Term Output Drift	< 2% /month (*)
Expected Life Time	> 2 years (*)
Operating Temperature	-20 ~ 50°C
Operating Humidity	15 ~ 90% RH
Operating Pressure Range	1013 hPa ±10%
Recommended Load Resistor	10Ω
Bias Voltage	+300 mV
Position Sensitivity	None
Recommended Storage Temp.	0 ~ 20°C
Storage Life	6 months
Cap Color	Orange
Weight	4.5g (approx.)

(*) Performance data conditions: 20°C, 50%RH and 1013 hPa.

Cross Sensitivity Data :

Table1 shows the typical response of FECS41-250 to interference gases.

Table1 Cross Sensitivity of FECS41-250 (20C)

Gas	Concentration (ppm)	Typical Nitric Oxide Concentration(ppm)Equivalent
Nitric Oxide	100	100
Carbon Monoxide	300	0
Carbon Dioxide	5,000	0
Hydrogen	1,000	0
Nitrogen Dioxide	5	< 1
Chlorine	10	0
Hydrogen Sulfide	15	< 4
Sulphur Dioxide	20	0
Ammonia	20	0

Dimensions:

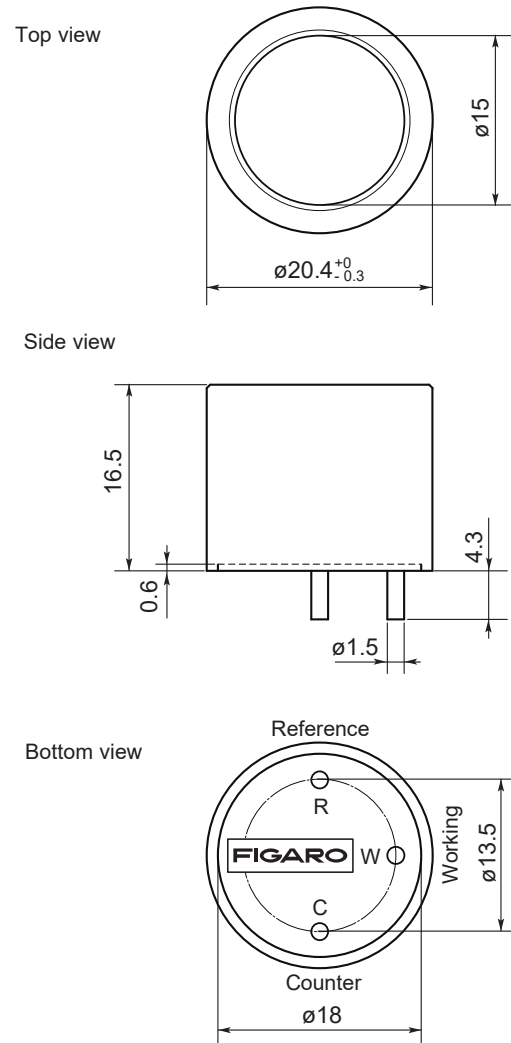

All dimensions in mm.

All tolerance ± 0.1mm unless otherwise stated.