

LPM2610-D09 pre-calibrated module for LP Gas

Features:

- * Factory calibrated
- * Temperature compensation circuit
- * Interferent-resistant sensor TGS2610
- * Compact size
- * Meets RoHS regulations

Applications:

- * Residential LP gas alarm

The LPM2610 is a pre-calibrated module for LP gas alarms which is precisely calibrated in Figaro's humidity and temperature controlled facility. The module uses TGS2610-D00 which incorporates a filter to eliminate the influence of interference gases such as alcohol, resulting in highly selective response to LP gas.

The most important process in manufacturing reliable residential gas alarms is adjusting the alarm point. Calibration is a complicated and time consuming process which also requires a substantial investment in calibration equipment. By eliminating the costly calibration process, this module enables users to easily and simply manufacture residential LP gas alarms. Figaro has taken the complexity out of designing a gas detector circuit by providing users with a temperature compensation circuit which combines a built-in thermistor and individually adjustable load resistor together with Figaro's low power LP gas sensor.

A connector allows easy replacement of the module for the purpose of periodic sensor renewal. This input/output connector enables easy installation of the module into the gas detectors' mother board. This same mother board can be used for both methane and LP gas detectors by simply changing the module.

This module is designed to meet the performance requirements of EN50194 and UL1484.

Please refer to "Technical Information for TGS2610" for sensor sensitivity characteristics. Refer to Application Notes for TGS2610 for further information regarding circuit design.

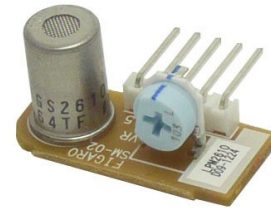

Circuit Diagram

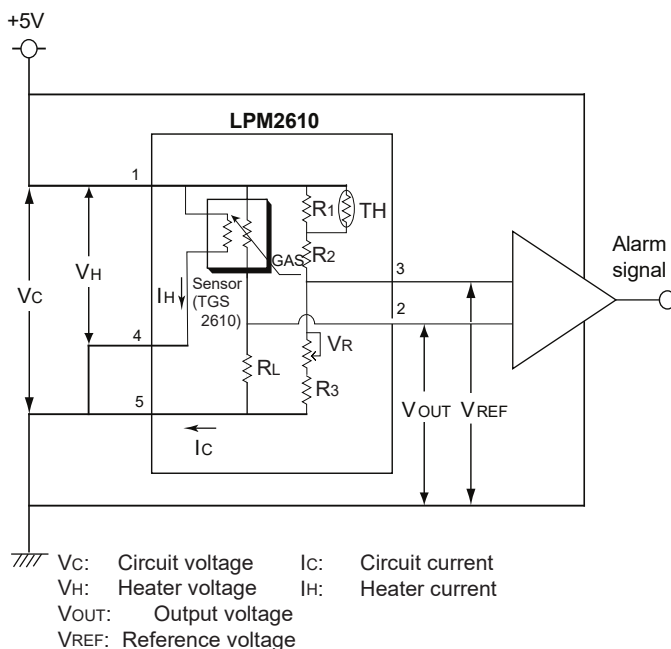

Basic Pin Connection

A regulated voltage of 5V DC should be applied to Pin #1. A voltage comparator should be connected to Pins #2 and 3. A circuit for detecting breakage of the heater may be connected to Pin #4 (in which case, Pins #4 and 5 should be connected separately to the GND).

When the gas sensor module is exposed to a concentration of target gas which exceeds the desired alarming point, the value of V_{out} will reach or exceed the value of V_{REF} , causing the module to reach the alarm condition.

NOTE: As described in Sec. 2-6 of Technical Information for TGS2610, when energizing the sensor after an unpowered period, the sensor's resistance (R_s) drops sharply for the first few seconds after energizing, regardless of the presence of gases, before recovering to a stable level. This 'initial action' may cause activation of an alarm during the first few moments of energizing since V_{RL} would exceed V_{ref} . To prevent unnecessary alarms during sensor warmup, a circuit modification such as that shown in Sec. 1-7 of "Application Notes for TGS2610" should be used.

IMPORTANT NOTE: OPERATING CONDITIONS IN WHICH FIGARO SENSORS ARE USED WILL VARY WITH EACH CUSTOMER'S SPECIFIC APPLICATIONS. FIGARO STRONGLY RECOMMENDS CONSULTING OUR TECHNICAL STAFF BEFORE DEPLOYING FIGARO SENSORS IN YOUR APPLICATION AND, IN PARTICULAR, WHEN CUSTOMER'S TARGET GASES ARE NOT LISTED HEREIN. FIGARO CANNOT ASSUME ANY RESPONSIBILITY FOR ANY USE OF ITS SENSORS IN A PRODUCT OR APPLICATION FOR WHICH SENSOR HAS NOT BEEN SPECIFICALLY TESTED BY FIGARO.

Parts List:

Symbol	Part	Spec.	Qty
R1	Carbon resistor	43kΩ	1
R2	Carbon resistor	1.0kΩ	1
R3	Carbon resistor	2.7kΩ	1
RL	Carbon resistor	1.1~4.7kΩ	1
VR	Potentiometer	10kΩ	1
TH	Thermistor	10kΩ at 25°C B const=3370±1%	1
Sensor	Gas Sensor	Figaro TGS2610-D00	1
CN	Connector	Nichiatsu MB5P-90S	1

Specifications:

Module No.			LPM2610-D09
Standard test conditions	Test gas conditions	1250±100ppm iso-butane in air at 20±2°C, 65±5%RH	
	Circuit conditions	V _H =5.0±0.05V DC V _C =5.0±0.05V DC	
	Preheating period prior to test	2 days	
Electrical characteristics under standard test conditions	Reference voltage	V _{REF(STD)}	1.4~3.0V DC
	Output voltage	V _{OUT(STD)}	1.4~3.0V DC

Electrical Characteristics:

Recommended operating conditions	Heater voltage	V _H	5.0±0.2V DC
	Circuit voltage	V _C	5.0±0.2V DC
	Minimum impedance between Pin#2 and GND	2.5MΩ	
	Minimum impedance between Pin#3 and GND		
	Operating conditions	0°~40°C, 30~95%RH	
Temperature differential between inside and outside detector casing	≤10°C max. (see NOTE 1)		
Electrical characteristics under operating conditions	Heater current (current between Pins #1 and 4)	I _H	56±5mA
	Circuit current (current between Pins #1 and 5)	I _C	10mA (max)
	Reference voltage	V _{REF}	0.8~3.5V DC (see NOTE 2)
	Output voltage (0~7200ppm iso-butane in air)	V _{out}	0.05~4.0V DC (see NOTE 3)

Structure and Dimensions:

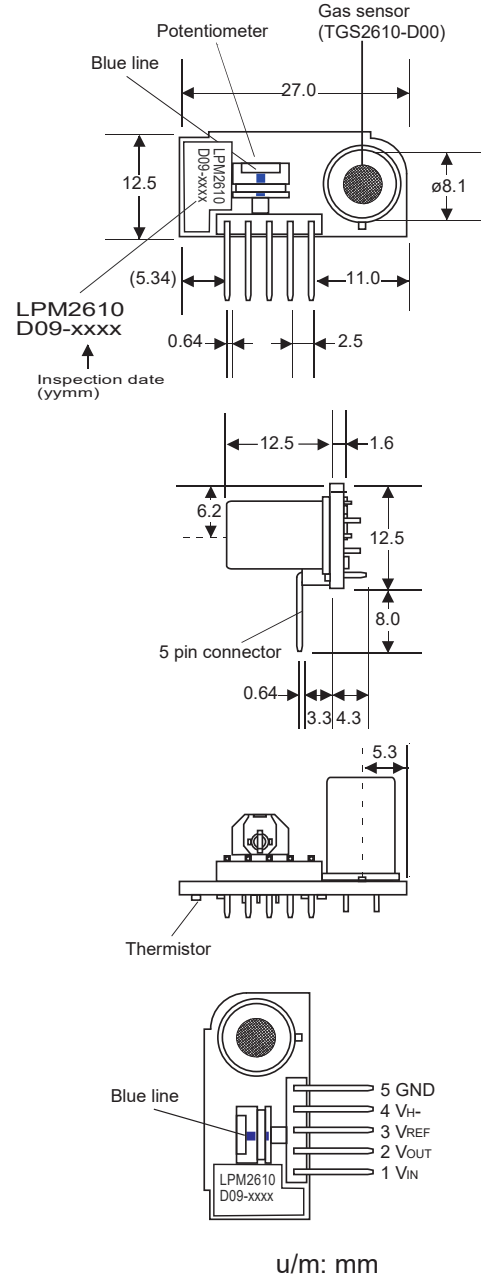

IMPORTANT NOTE: The original setting of the potentiometer should be checked prior to usage of the module to verify that it is in the calibrated position. LPM2610 has a blue line on the potentiometer which should be in alignment.

Expected performance:

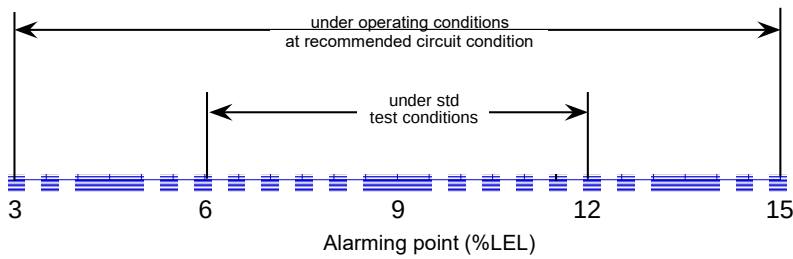

Expected performance of LP gas detectors using LPM2610 and 9% LEL alarming point

NOTE: When using LPM2610, typical alarm tolerances for 9%LEL of methane gas such as those shown in the figure above can be expected. However, in actual usage, alarm thresholds may vary since the threshold is also affected by such factors as the tolerances of test conditions and heat generation inside the gas detection enclosure. As a result, Figaro neither expressly nor impliedly warrants the performance shown in this figure. If a large difference between the expected and actual performance of detectors is noticed, please consult with Figaro.

Absolute Maximum Ratings:

Absolute maximum ratings (see NOTE 4)	Circuit voltage	V _C	-0.3~+6.0V DC
	Heater voltage	V _H	-0.3~+5.5V DC (max of 2 minutes at 5.5V)
	Operating temperature		-15°~+55°C (max 95%RH)
	Storage temperature		-20°~+60°C (avoid condensation)
	Soldering temperature		260°C (max in 10 sec.)

NOTE 1: Due to heat generated by circuit components, if the internal temperature of the detector exceeds the environmental temperature outside the detector casing by 10°C or more, the calibrated alarm concentration would drift due to drifting of V_{ref}. If users are unable to design detectors so as to keep this temperature differential below 10°C, please consult with Figaro.

NOTE 2: Reference voltage may be out of range if temperature exceeds recommended operating conditions.

NOTE 3: Output voltage maybe out of range under the following conditions:

* Iso-butane concentration exceeds 7200ppm

* During warm-up period (due to 'initial action' -- refer to "Item 2-6 - Initial Action" in p.7 of *Technical Information for TGS2610*)

Accordingly, a malfunction threshold is STRONGLY RECOMMENDED to be implemented when using LPM2610-D09.

** Recommended malfunction threshold:

1.0V DC > V_{ref} > 4.0V DC

0.05V DC > V_{out} > (V_C-0.05)V DC

NOTE 4: Detectors should be designed according to "Recommended Operating Conditions" as shown above. However, detector circuits should also be designed not to exceed "Absolute Maximum Ratings" under any circumstances. To exceed these ratings may cause damage or deterioration of the sensor.

For applications involving usage of LPM2610 for applications other than residential LP gas alarms, please consult with Figaro.

