

# TGS 2620 for the detection of Solvent Vapors

### Features:

- \* Low power consumption
- \* High sensitivity to alcohol and organic solvent vapors
- \* Long life and low cost
- \* Uses simple electrical circuit

The sensing element is comprised of a metal oxide semiconductor layer formed on an alumina substrate of a sensing chip together with an integrated heater. In the presence of a detectable gas, the sensor's conductivity increases depending on the gas concentration in the air. A simple electrical circuit can convert the change in conductivity to an output signal which corresponds to the gas concentration.

The **TGS 2620** has high sensitivity to the vapors of organic solvents as well as other volatile vapors, making it suitable for organic vapor detectors/alarms.

Due to miniaturization of the sensing chip, TGS 2620 requires a heater current of only 42mA and the device is housed in a standard TO-5 package.

### Applications:

- \* Alcohol testers
- \* Organic vapor detectors/alarms
- \* Solvent detectors for factories, dry cleaners, and semiconductor industries

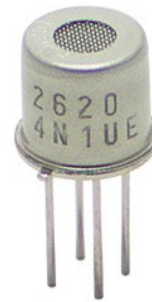

The figure below represents typical sensitivity characteristics, all data having been gathered at standard test conditions (see reverse side of this sheet). The Y-axis is indicated as sensor resistance ratio ( $R_s/R_o$ ) which is defined as follows:

- $R_s$  = Sensor resistance in displayed gases at various concentrations
- $R_o$  = Sensor resistance in 300ppm of ethanol

The figure below represents typical temperature and humidity dependency characteristics. Again, the Y-axis is indicated as sensor resistance ratio ( $R_s/R_o$ ), defined as follows:

- $R_s$  = Sensor resistance in 300ppm of ethanol at various temperatures/humidities
- $R_o$  = Sensor resistance in 300ppm of ethanol at 20°C and 65% R.H.

**Sensitivity Characteristics:**

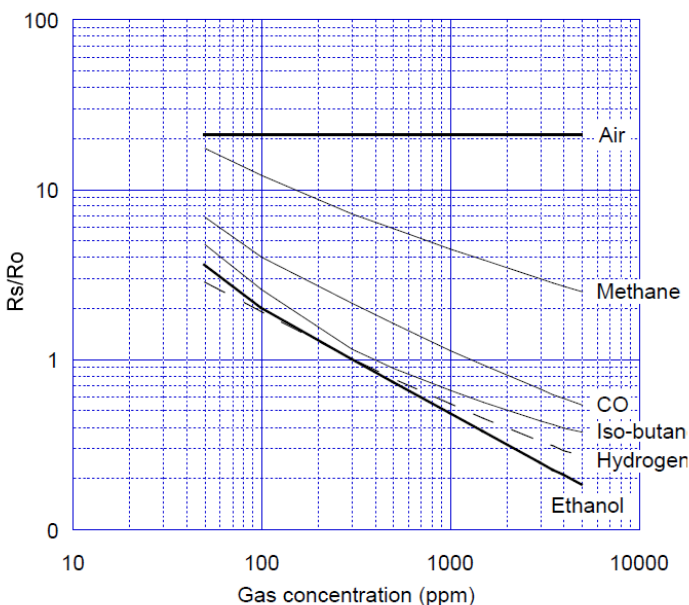

**Temperature/Humidity Dependency:**

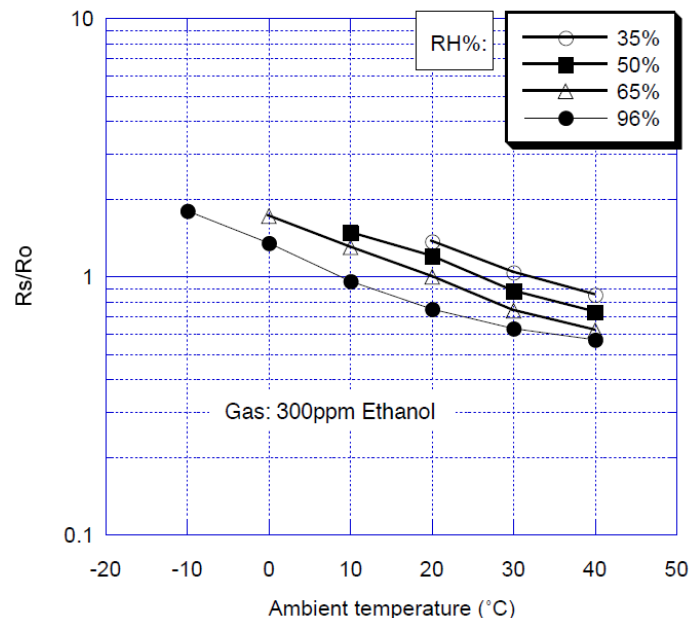

**IMPORTANT NOTE:** OPERATING CONDITIONS IN WHICH FIGARO SENSORS ARE USED WILL VARY WITH EACH CUSTOMER'S SPECIFIC APPLICATIONS. FIGARO STRONGLY RECOMMENDS CONSULTING OUR TECHNICAL STAFF BEFORE DEPLOYING FIGARO SENSORS IN YOUR APPLICATION AND, IN PARTICULAR, WHEN CUSTOMER'S TARGET GASES ARE NOT LISTED HEREIN. FIGARO CANNOT ASSUME ANY RESPONSIBILITY FOR ANY USE OF ITS SENSORS IN A PRODUCT OR APPLICATION FOR WHICH SENSOR HAS NOT BEEN SPECIFICALLY TESTED BY FIGARO.

### Basic Measuring Circuit:

The sensor requires two voltage inputs: heater voltage ( $V_H$ ) and circuit voltage ( $V_C$ ). The heater voltage ( $V_H$ ) is applied to the integrated heater in order to maintain the sensing element at a specific temperature which is optimal for sensing. Circuit voltage ( $V_C$ ) is applied to allow measurement of voltage ( $V_{OUT}$ ) across a load resistor ( $R_L$ ) which is connected in series with the sensor.

A common power supply circuit can be used for both  $V_C$  and  $V_H$  to fulfill the sensor's electrical requirements. The value of the load resistor ( $R_L$ ) should be chosen to optimize the alarm threshold value, keeping power consumption ( $P_S$ ) of the semiconductor below a limit of 15mW. Power consumption ( $P_S$ ) will be highest when the value of  $R_S$  is equal to  $R_L$  on exposure to gas.

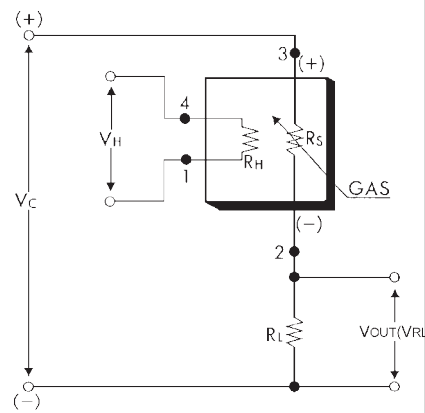

### Specifications:

Model number		TGS2620-C00	
Sensing principle		MOS-type	
Standard package		TO-5 metal can	
Target gases		Alcohol, Solvent vapors	
Typical detection range		50 ~ 5,000ppm EtOH	
Standard circuit conditions	Heater voltage	$V_H$	5.0±0.2V AC/DC
	Circuit voltage	$V_C$	5.0±0.2V DC $P_S \leq 15mW$
	Load resistance	$R_L$	variable      0.45kΩ min.
Electrical characteristics under standard test conditions	Heater resistance	$R_H$	83Ω at room temp. (typical)
	Heater current	$I_H$	42±4mA
	Heater power consumption	$P_H$	210mW (typical)
	Sensor resistance	$R_S$	1kΩ ~ 5kΩ in 300ppm ethanol
	Sensitivity (change ratio of $R_S$ )		0.3~0.5 in ethanol $\frac{R_S(300ppm)}{R_S(50ppm)}$
Standard test conditions	Test gas conditions	Ethanol vapor in air at 20±2°C, 65±5%RH	
	Circuit conditions	$V_C = 5.0 \pm 0.01V$ DC $V_H = 5.0 \pm 0.05V$ DC	
	Conditioning period before test	7 days	

### Structure and Dimensions:

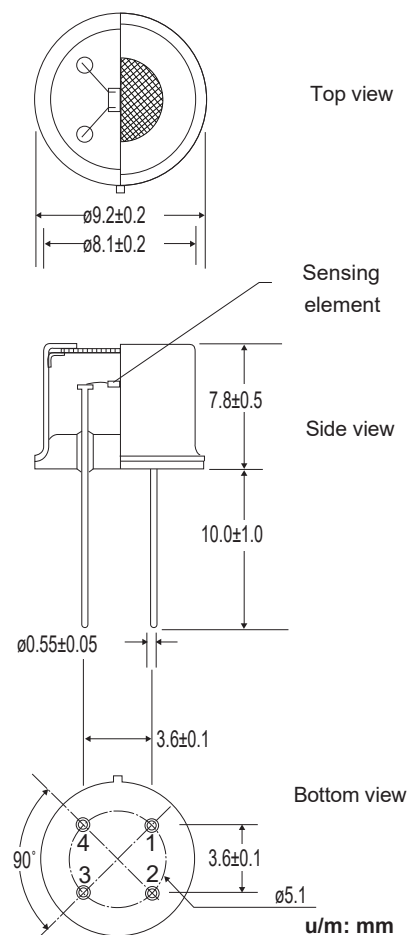

#### Pin connection:

- 1: Heater
- 2: Sensor electrode (-)
- 3: Sensor electrode (+)
- 4: Heater

The value of power dissipation ( $P_S$ ) can be calculated by utilizing the following formula:

$$P_S = \frac{V_C - V_{RL}}{R_S}^2$$

Sensor resistance ( $R_S$ ) is calculated with a measured value of  $V_{OUT}(V_{RL})$  by using the following formula:

$$R_S = \left( \frac{V_C}{V_{RL}} - 1 \right) \times R_L$$

