

# TGS 2630 for the detection of Refrigerant Gases

### Features:

- \* High sensitivity to low-flammable refrigerant gases
- \* Improved selectivity
- \* Uses simple electrical circuit
- \* Low power consumption

### Applications:

- \* Refrigerant gas leak detection in air conditioning/refrigeration systems

The sensing element of Figaro gas sensors is a tin dioxide (SnO<sub>2</sub>) semiconductor which has low conductivity in clean air. In the presence of a detectable gas, the sensor's conductivity increases depending on the gas concentration in the air. A simple electrical circuit can convert the change in conductivity to an output signal which corresponds to the gas concentration.

**TGS 2630** has high sensitivity to low GWP (Global Warming Potential), low-flammable refrigerant gases such as R-32 and R-1234yf, as well as to R-404a and R-410a which are commonly used in air conditioning and refrigeration systems. TGS2630 uses filter material in its housing to eliminate the influence of interference gases such as alcohol, resulting in highly selective response to low-flammable refrigerant gases. This feature makes the sensor ideal for stationary type leakage detectors which require durability and resistance against interference gas. Due to miniaturization of the sensor chip, TGS2630 requires a heater current of only 56mA and the device is housed in a standard TO-5 package.



The figure below represents typical sensitivity characteristics, all data having been gathered at standard test conditions (see reverse side of this sheet). The Y-axis is indicated as sensor resistance ratio (Rs/Ro) which is defined as follows:

Rs = Sensor resistance of displayed gases at various concentrations

Ro = Sensor resistance at 5000ppm of R-32

The figure below represents typical temperature dependency characteristics. Again, the Y-axis is indicated as sensor resistance ratio (Rs/Ro), defined as follows:

Rs = Sensor resistance at various concentrations of each gas at various temperatures/40%RH

Ro = Sensor resistance at 5000ppm of R-32 at 20°C/40% R.H.

### Sensitivity Characteristics:

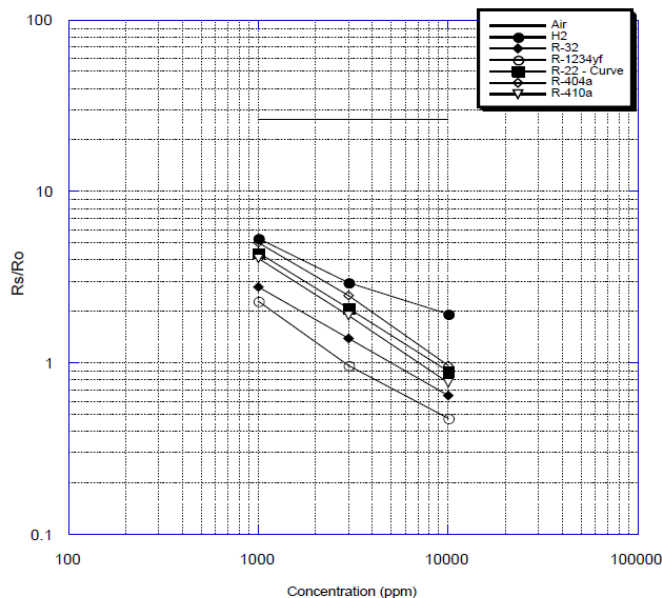

### Temperature Dependency:

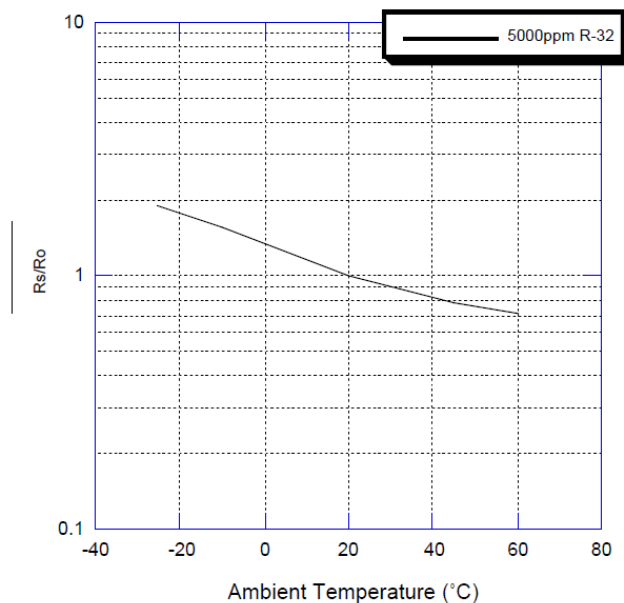

**IMPORTANT NOTE:** OPERATING CONDITIONS IN WHICH FIGARO SENSORS ARE USED WILL VARY WITH EACH CUSTOMER'S SPECIFIC APPLICATIONS. FIGARO STRONGLY RECOMMENDS CONSULTING OUR TECHNICAL STAFF BEFORE DEPLOYING FIGARO SENSORS IN YOUR APPLICATION AND, IN PARTICULAR, WHEN CUSTOMER'S TARGET GASES ARE NOT LISTED HEREIN. FIGARO CANNOT ASSUME ANY RESPONSIBILITY FOR ANY USE OF ITS SENSORS IN A PRODUCT OR APPLICATION FOR WHICH SENSOR HAS NOT BEEN SPECIFICALLY TESTED BY FIGARO.

### Basic Measuring Circuit:

The sensor requires two voltage inputs: heater voltage ( $V_H$ ) and circuit voltage ( $V_C$ ). The heater voltage ( $V_H$ ) is applied to the integrated heater in order to maintain the sensing element at a specific temperature which is optimal for sensing. Circuit voltage ( $V_C$ ) is applied to allow measurement of voltage ( $V_{OUT}[V_{RL}]$ ) across a load resistor ( $R_L$ ) which is connected in series with the sensor.

A common power supply circuit can be used for both  $V_C$  and  $V_H$  to fulfill the sensor's electrical requirements. The value of the load resistor ( $R_L$ ) should be chosen to optimize the alarm threshold value, keeping power consumption ( $P_S$ ) of the semiconductor below a limit of 15mW. Power consumption ( $P_S$ ) will be highest when the value of  $R_S$  is equal to  $R_L$  on exposure to gas.

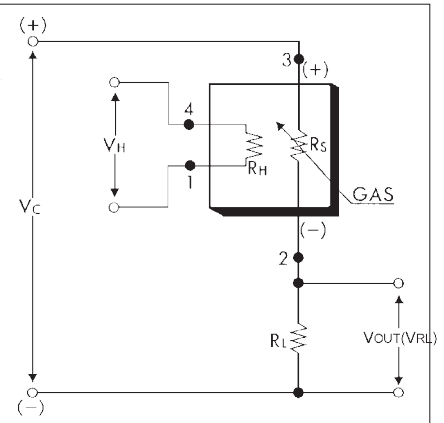

### Specifications

Model number		TGS2630	
Sensing principle		MOS type	
Standard package		TO-5 metal can	
Target gases		Refrigerant gases	
Typical detection range		1,000 ~ 10,000ppm	
Standard circuit conditions	Heater voltage	$V_H$	5.0±0.2V AC/DC
	Circuit voltage	$V_C$	5.0±0.2V DC $P_S \leq 15mW$
	Load resistance	$R_L$	variable    0.45kΩ min.
Electrical characteristics under standard test conditions	Heater resistance	$R_H$	59Ω at room temp. (typical)
	Heater current	$I_H$	56±5mA
	Heater power consumption	$P_H$	280mW $V_H=5.0V$ DC
	Sensor resistance	$R_S$	0.46kΩ ~ 10kΩ in 5000ppm R-32
	Sensitivity (change ratio of $R_S$ )		0.2~0.7 in R-32 $\frac{R_S(9000ppm)}{R_S(3000ppm)}$
Standard test conditions	Test gas conditions	R-32 in air at 20±2°C, 65±5%RH	
	Circuit conditions	$V_C = 5.0 \pm 0.01V$ DC $V_H = 5.0 \pm 0.05V$ DC	
	Conditioning period before test	7 days	

The value of power dissipation ( $P_S$ ) can be calculated by utilizing the following formula:

$$P_S = \frac{C - V_{RL}}{R_S}^2$$

Sensor resistance ( $R_S$ ) is calculated with a measured value of  $V_{OUT}[V_{RL}]$  by using the following formula:

$$R_S = \left( \frac{C}{V_{RL}} - 1 \right) \times R_L$$

All sensor characteristics shown in this brochure represent typical characteristics. Actual characteristics vary from sensor to sensor. The only characteristics warranted are those in the Specification table above.

REV: 07/17

### Structure and Dimensions:

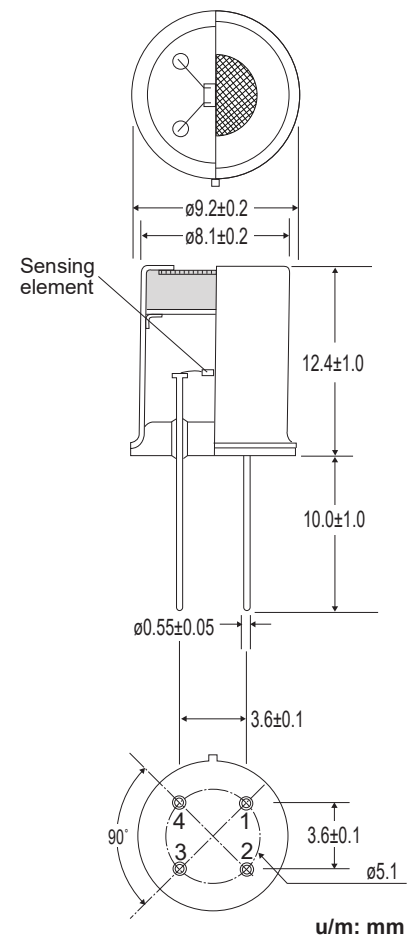

#### Pin connection:

- 1: Heater
- 2: Sensor electrode (-)
- 3: Sensor electrode (+)
- 4: Heater



[info@diltronics.com](mailto:info@diltronics.com)

(33) 01 34 51 33 00