

# TGS 5141-P00 for the detection of Carbon Monoxide

### Features:

- \* Ultra compact
- \* Battery operable
- \* High repeatability/selectivity to CO
- \* Linear relationship between CO gas concentration and sensor output
- \* Simple calibration
- \* Long life
- \* UL recognized component
- \* Meets UL2034, EN50291, and EN54-31 requirements

### Applications:

- \* Residential and commercial CO detectors
- \* Fire detection

Figaro's **TGS5141** is a battery operable electrochemical sensor which uses a unique electrolyte that eliminates the need for a water reservoir. By eliminating the water reservoir used in TGS5042, the comparative size of TGS5141 is reduced to just 10% of TGS5042. With its ultra compact size, this sensor is the ideal choice for size oriented applications such as portable CO detectors, small residential CO detectors, and multi-sensor fire detectors. OEM customers will find individual sensors data printed on each sensor in bar code form, enabling users to skip the costly gas calibration process and allowing for individual sensor tracking.



The figure below represents typical sensitivity characteristics, all data having been gathered at standard test conditions (see reverse side of this sheet). The Y-axis shows the output current of the sensor ( $I_{out}/\mu A$ ) in each gas. Output current is linear to CO concentration, with a deviation of less than  $\pm 5\%$  in the range of 0~500ppm.

### Sensitivity Characteristics:

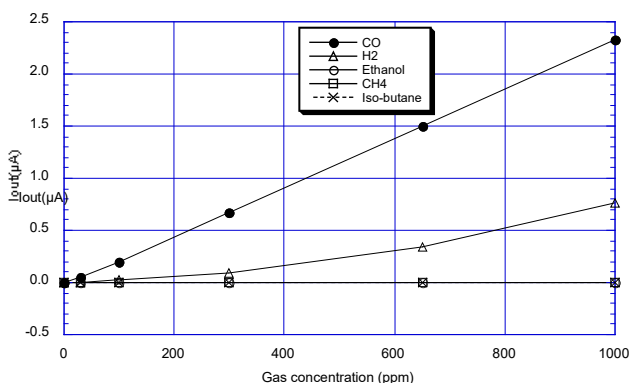

The figure below represents typical temperature dependency characteristics. The Y-axis shows the sensor output ratio ( $I/I_0$ ) as defined below. The linear relationship between  $I/I_0$  and CO concentration is constant regardless of the CO concentration range.

$I$  = Sensor output current in 400ppm of CO at various temperatures

$I_0$  = Sensor output current in 400ppm at 20°C/50%RH

### Temperature Dependency:

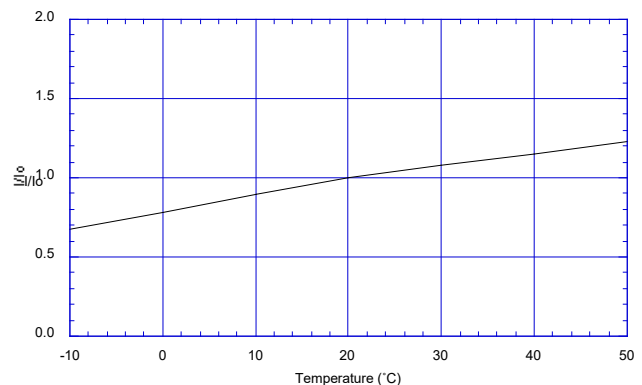

### Basic Measuring Circuit:

The diagram at the right shows the basic measuring circuit of TGS5141. The sensor generates a minute electric current which is converted into sensor output voltage (Vout) by an op-amp/resistor (R1) combination.

Figaro recommends the following electrical parts:

- R1 : 1MΩ
- C1 : 1μF
- IC : AD708

**NOTE:** When voltage is applied to the sensor output terminal, the sensor may be damaged. Voltage applied to the sensor should be strictly limited to less than ±10mV. An additional resistor or FET is required to prevent polarization of the sensor when Vc is off.

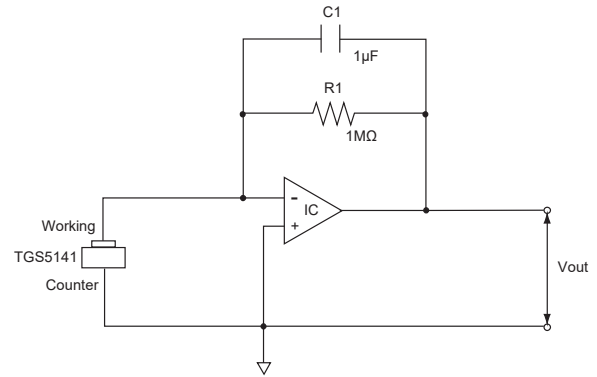

**Basic measuring circuit of TGS5141**

### Specifications:

Item	Specification
Model number	TGS5141-P00
Target gases	Carbon monoxide
Typical detection range	0 ~ 5,000ppm
Output current in CO	1.2~3.2nA/ppm
Baseline offset(*1)	<±10ppm equivalent
Operating temperature	-10°C ~ +50°C (continuous) -20°C ~ +60°C (intermittent)
Operating humidity	10 ~ 95%RH (no condensation)
Response time (T90)	within 60 seconds
Storage conditions	-10°C ~ +50°C (continuous) -20°C ~ +60°C (intermittent)
Weight	approx. 2.5g
Standard test conditions	20±2°C, 40±10%RH

(\*1) Represents sensor output in air under operating conditions

### Structure and Dimensions:

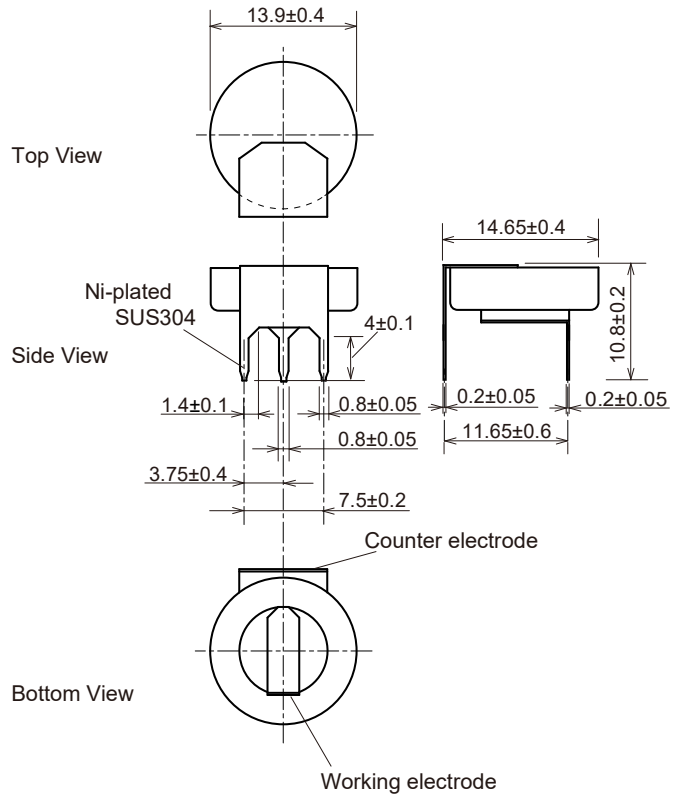

Unit : mm



[info@diltronic.com](mailto:info@diltronic.com)

(33) 01 34 51 33 00