

Contactless Angle Sensor

# CP36U Series

TMR Element Contactless Angle Sensor  
Equipped with Microcomputer

- Contactless Angle Sensor
  - Effective Electrical Travel : 18°~360°
  - Absolute Linearity :  $\pm 0.2\%FS$  ( $FS=360^\circ$ )
  - 2 wire type Current Output
  - Teach-in function (Zero-Span adjustment, etc.) is available
  - Robust Housing : IP67 type is available
- 【Option】
- Mounting plate type is available.

## ◆ Useful Teach-in Function (Adjusting Switch Unit (ASW-Unit))

The programmable type of CP36U Series provides the following user-adjustable functions by using the SWU-unit.



ASU-unit

### ~Offering two types of ASW-unit~

[Fixed Cable type]---The ASW-Unit has installed on the fixed wiring cable of the sensor. The unit is unremovable from the cable.

[Detachable Cable type]---The ASW-Unit is removable from the wiring cable of the sensor, and it can be shared use with other programmable CP-36U. The ASW-Unit is available to be purchased separately.

### • Teach-in Electrical Angle Range

① Setting start (ST) and end (ED) to arbitrary positions.

The accuracy assurance range :  $FS=18^\circ \cdot 1 \sim 360^\circ$

FS adjustable angle range :  $1^\circ \sim 360^\circ \cdot 2$

### • Zero/Span Adjustment

② ZERO Adj.:  $4mA \pm 1mA$  Adj.

③ SPAN Adj.:  $20mA \pm 1mA$  Adj.

Adjustable Resolution:  $4.55 \mu A$  approx.

### • Output increase direction Setting

④ Output increasing direction setting to CW

⑤ Output increasing direction setting to CCW

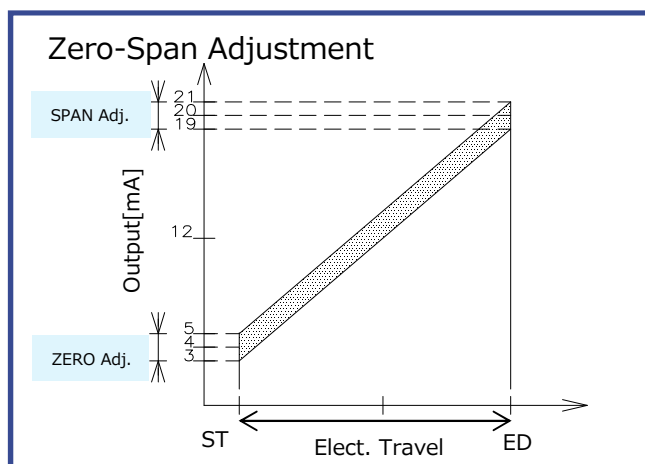

※<sup>1</sup> Less than  $FS=18^\circ$  is also a settable range, but out of the assurance range.

※<sup>2</sup> If FS is set less than  $1^\circ$  or more than  $359^\circ$ , FS will be automatically reset to  $360^\circ$

### ~Misoperation Prevention Function~

To avoid the unintended output adjustment result, the setting will not be effective without pressing the "S (SET)" button. The protective cover to prevent accidentally press the buttons is also attached to the unit.

## Specifications

Specifications	Non-Adjustable type			Adjustable type	
	360~271	270~91	90~18		
Effective Elect. Travel	360~271	270~91	90~18	360~18	°
Absolute Linearity	±0.2	±0.3	±0.5	±0.2~±2.1	%FS
Output Range	4~20			Resettable (4±1,20±1,CW,CCW)	mA
Input Voltage	24±8				Vdc
Load Resistance	600 max. (Vin= @DC24V)				Ω
Update Cycle	1k±10%				Hz
Resolution	4.55Typ.(Calculation, 12bit approx.)			It depends on angle	μA
Category Temp. Range	-40~+85				°C
Storage Temp. Range	-40~+105				°C
Temp. Drift (Category Temp. Range)	±1.0		±0.5	±1.0 (FS=360°~91°) ±0.5 (FS=90°~18°)	°
IP Rating	IP50 / IP67 (Except cable exit)				
Rotational Torque	1mN · m max.(IP50) / 10mN · m max.(IP67)				
Vibration	200m/s <sup>2</sup> 5~500Hz/20分 3 axis 2h each (JIS C60068-2)				
Shock	1000m/s <sup>2</sup> 6ms 3 axis 6 directions 3 times each (JIS C60068-2-27)				
EMS	100V/m : 10k~1GHz (ISO11452-2,3)			-	
EMI	CISPR25 CLASS2				
ESD	IEC61000-4-2 Contact ±4kV, Air ±8kV, Criteria B				

\* For details on how to use the ASW-Unit, please refer the document which is called "How to use the ASW-Unit".

● Angle/Resolution/Linearity of w/ASW-unit type  
If the unit is adjusted by each user, the linearity and resolution will be changed as shown in the table below.

Travel	Linearity	Resolution
FS=360°	0.2%FS	12bit approx.
>FS=180°	0.3%FS	12bit approx.
>FS=90°	0.5%FS	12bit approx.
>FS=45°	0.9%FS	11bit approx.
>FS=30°	1.3%FS	10bit approx.
>FS=18°	2.1%FS	9bit approx.

## Output Characteristics

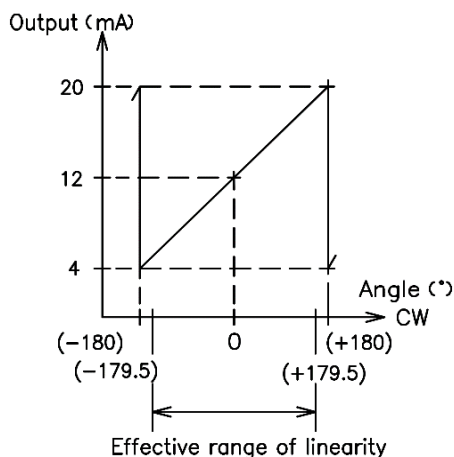

\*The output characteristics are typical examples of the 360° output type.

## Schematic

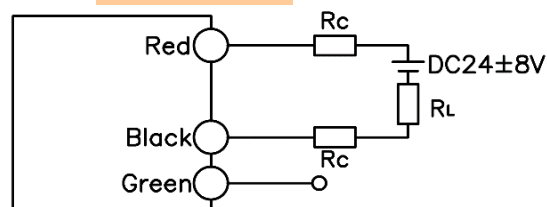

- Red, Black and Green indicate harness colors.
- Green is shield drain wire. Be grounded if necessary.
- Rc: Transmitting wire resistance
- RL: Load resistance

Dimension (mm)

Non-Adjustable type

Mounting plate type / Option

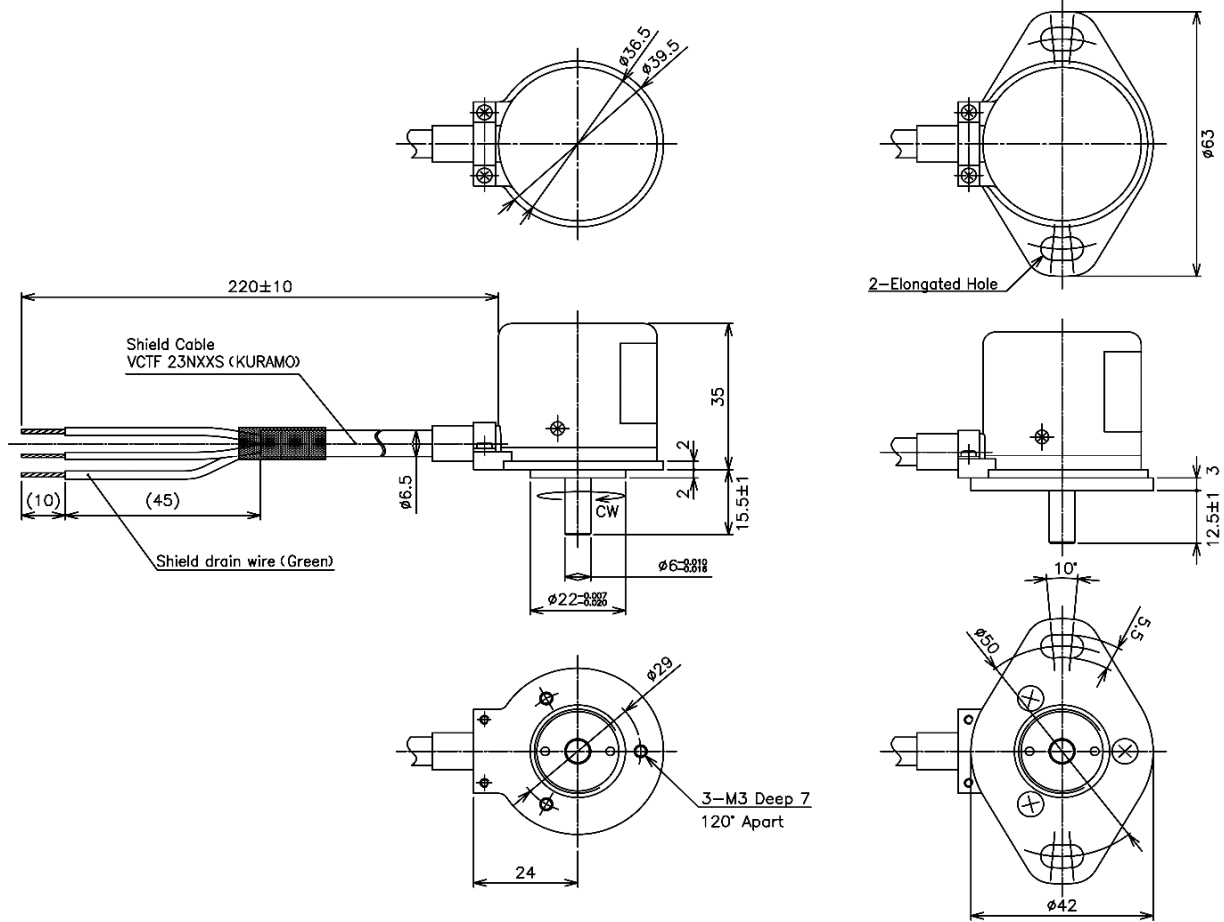

Dimension (mm)

Adjustable type / Fixed Cable type

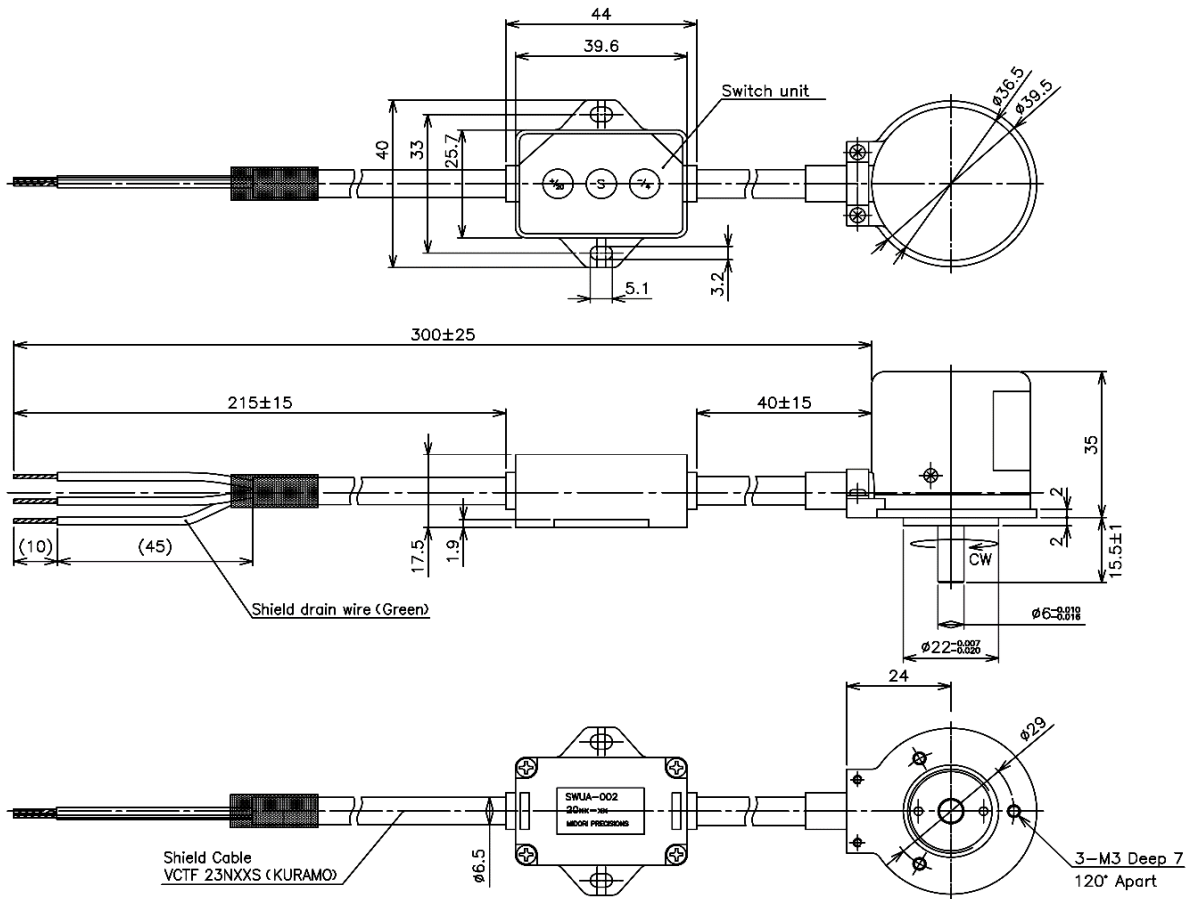

Dimension (mm)

Adjustable type / Detachable Cable type

Detached

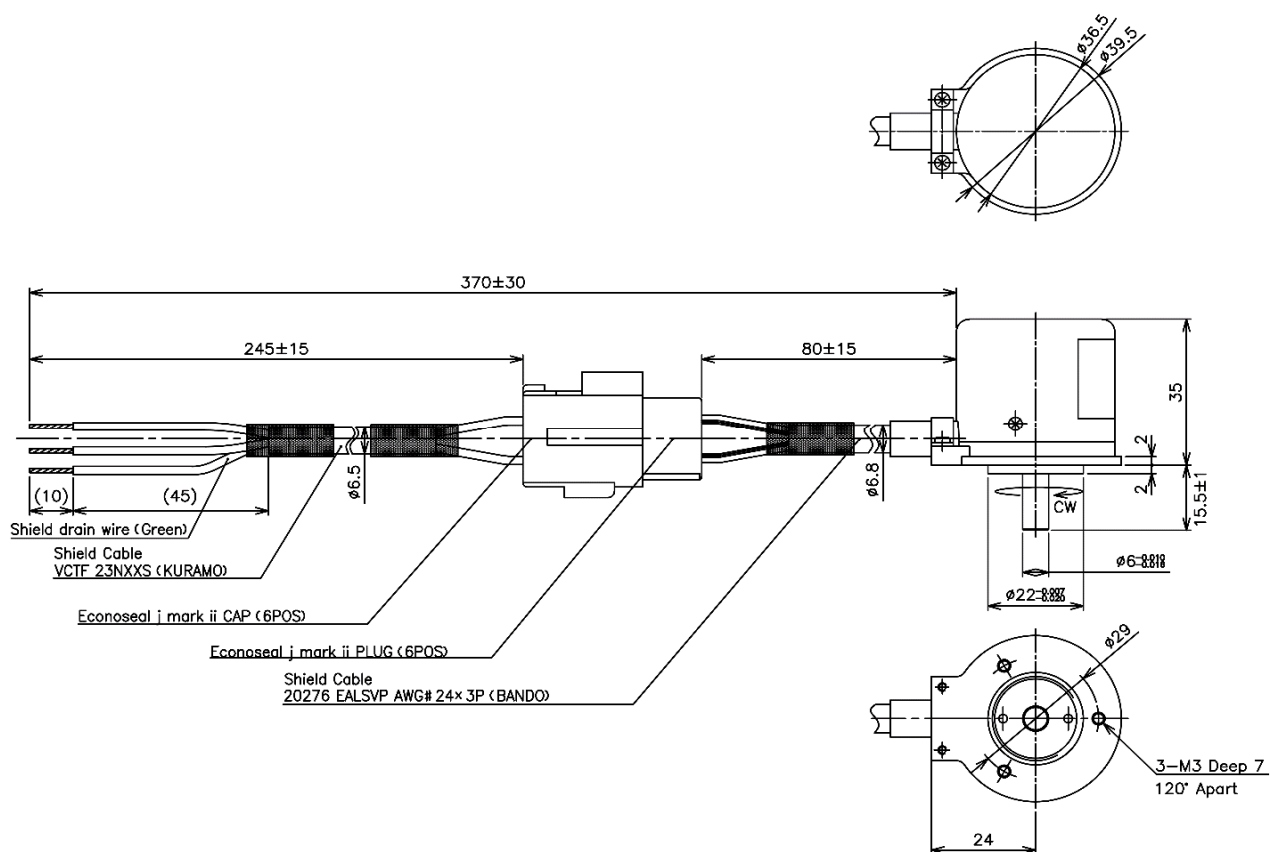

Dimension (mm)

Adjustable type / Detachable Cable type

Attached ASW-Unit

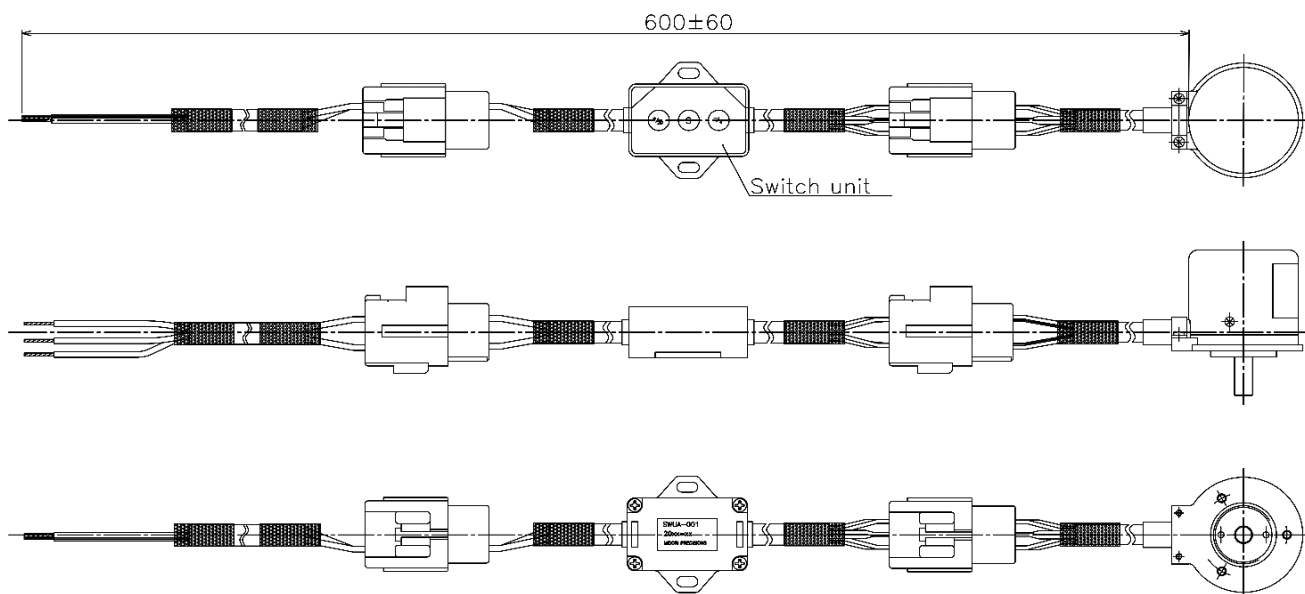

Dimension (mm)

ASW-Unit (Selling separately)

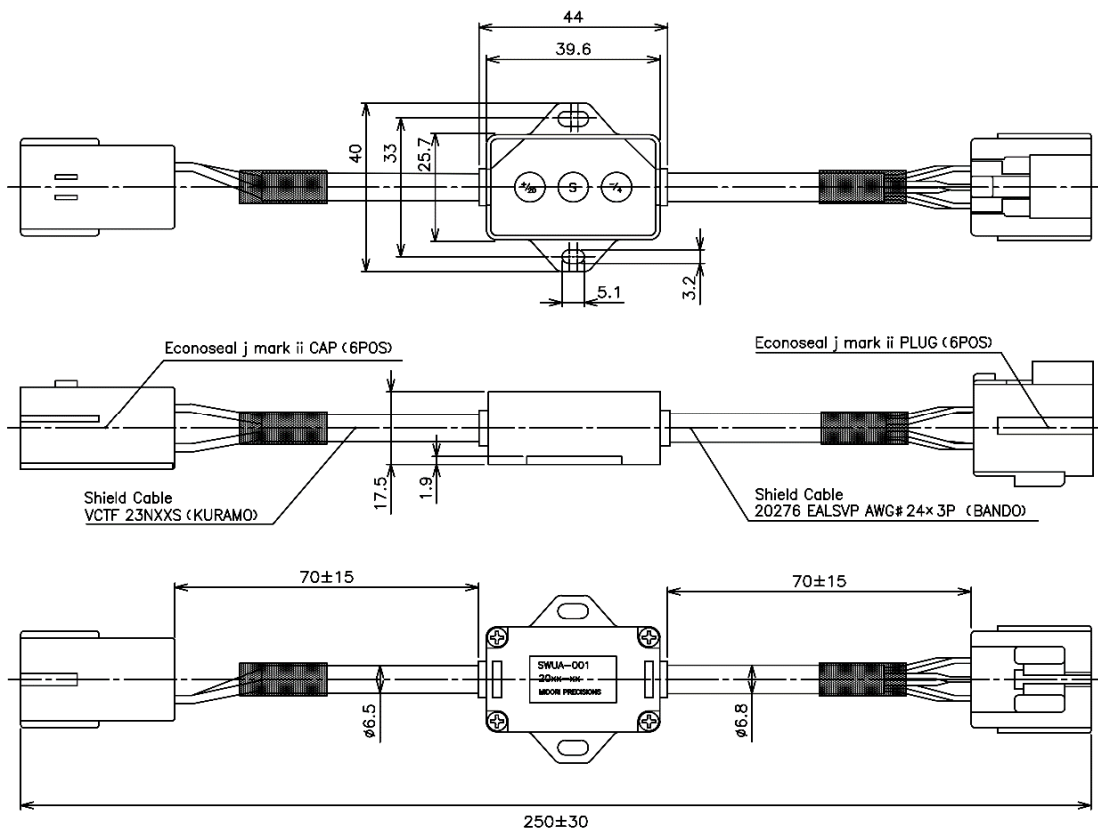

Mounting

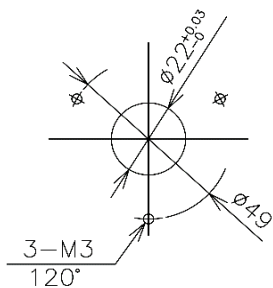

Servo Mount

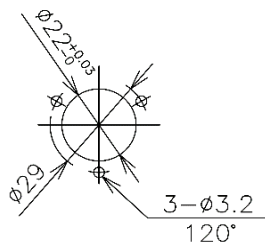

Screw Mount

Accessories

Cleats : 2pcs

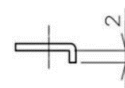
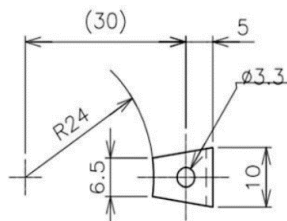

t=1.2

Mounting

Mounting plate type / Option

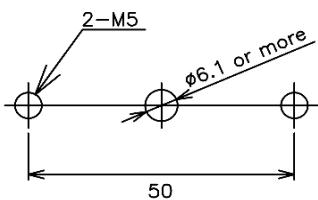

Accessories

Flat-Washers : 2pcs

Mounting

For ASW-Unit

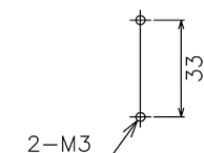

Accessories

Protection Cover : 1pc

## 【CP36U Series Model Number Designation】

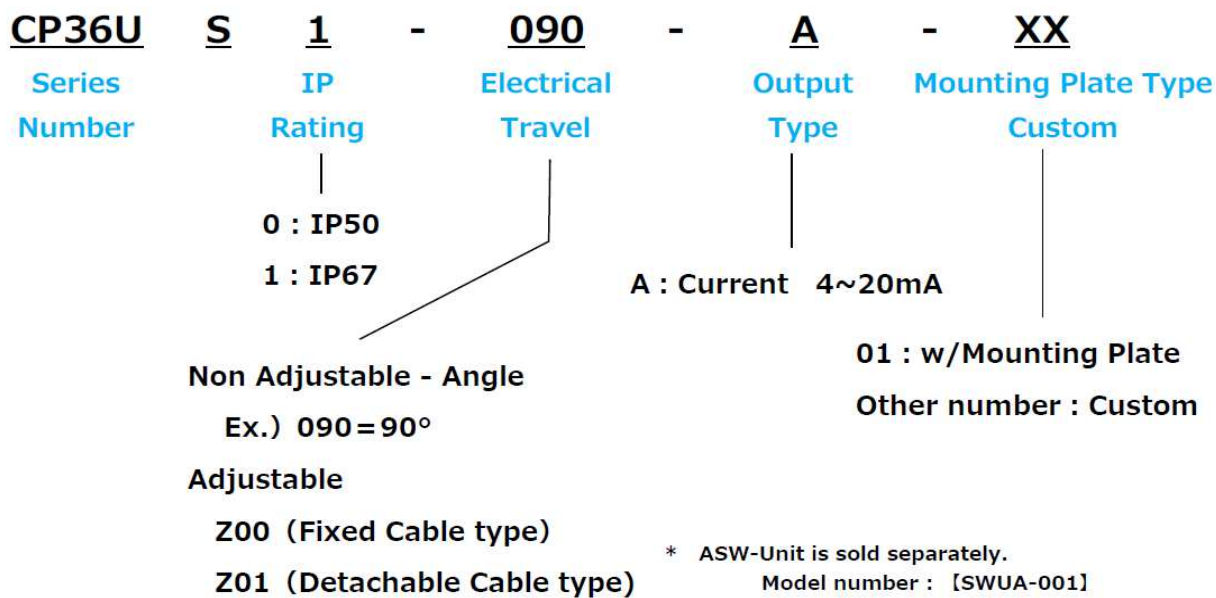

Ex : CP36US1-090-A . . . IP67,FS= 90°

CP36US0-360-A . . . IP50 ,FS=360°

CP36US1-Z01-A . . . IP67 , w/ Zero-Span adjustment (Detachable ASW-Unit)

### ■ Handling Instruction

- Do not connect other than above Schematic diagram.