



Silane Gas Sensor SiH4/C-50

SiH₄ Gas Sensor in Compact Housing

Key Features

- Highly sensitive SiH₄ measurement

Applications

- Discontinuous Measurement
- Safety and Process Control

Measurement

Operation Principle	3-Electrode Electrochemical
Nominal Range	0 - 50 ppm
Maximum Overload	100 ppm
Inboard Filter	-
Output Signal	1200 ± 400 nA/ppm
Resolution (Electronics dependent)	< 0.1 ppm
T90 Response Time	< 60 s
Typical Baseline Range (pure air, 20°C)	-0.5 ppm to 0.5 ppm
Maximum Zero Shift (+20°C to +40°C)	see Graph
Repeatability	< 2 % of signal
Output Linearity	Linear
Gain (Only applies to 4-Electrode sensors)	-

Performance data recorded at 20 – 25 °C, 30 - 50% RH, 900 - 1100 mbar

For further information about usage of Membrapor sensors, see application note [MEM1](#). The data contained in this document is for guidance only. Membrapor AG accepts no liability for any consequential losses, injury or damage resulting from the use of this document or from any omissions or errors herein. Customers should test under their own conditions to ensure that the sensors are suitable for their own requirements.



Silane Gas Sensor SiH₄/C-50

Electrical

Rec. Load Resistor	10 - 33 Ω
Bias (V_Sens-V_Ref)	not recommended
Conformity to RoHS directive	RoHS Compliance

Environmental

Relative Humidity Range	15 % to 90 % RH non-condensing
Temperature Range	-20 °C to 50 °C
Pressure Range	Atmospheric ± 10%
Pressure Coefficient	N.D.
Humidity Effect	None

Lifetime

Expected Operation Life	2 years in air
Expected Long Term Output Drift in air	< 2 % signal loss per month
Filter Life	
Storage Life	6 months in container
Rec. Storage Temperature	5°C - 20°C
Warranty Period	12 months from date of dispatch

Performance data recorded at 20 – 25 °C, 30 - 50% RH, 900 - 1100 mbar

For further information about usage of Membrapor sensors, see application note [MEM1](#). The data contained in this document is for guidance only. Membrapor AG accepts no liability for any consequential losses, injury or damage resulting from the use of this document or from any omissions or errors herein. Customers should test under their own conditions to ensure that the sensors are suitable for their own requirements.



Silane Gas Sensor SiH4/C-50

Compact-Size Outline Dimensions

BOTTOM VIEW

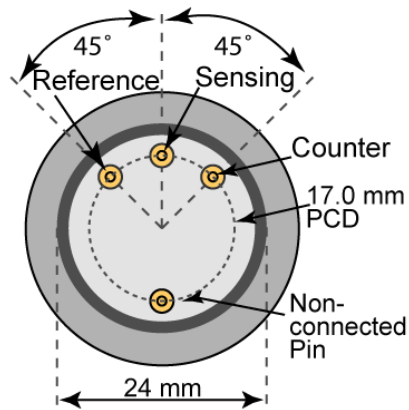

± 0.10 mm

SIDE VIEW

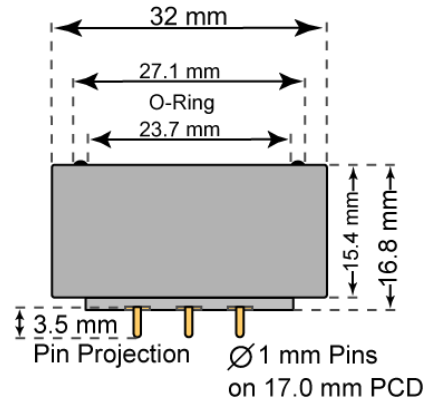

Mechanical

Weight	13 g
Orientation	Any
Housing material	Polycarbonate

Performance data recorded at 20 – 25 °C, 30 - 50% RH, 900 - 1100 mbar

For further information about usage of Membrapor sensors, see application note [MEM1](#). The data contained in this document is for guidance only. Membrapor AG accepts no liability for any consequential losses, injury or damage resulting from the use of this document or from any omissions or errors herein. Customers should test under their own conditions to ensure that the sensors are suitable for their own requirements.



Silane Gas Sensor SiH₄/C-50

Cross Sensitivity Data

The table below does not claim to be complete. Interfering gases should not be used for calibration. Please contact Membrapor AG for further support regarding cross sensitivities.

Interfering Gas	Concentration [ppm]	Reading [ppm]
AsH ₃	15	20
Cl ₂	20	-3.5
CO	200	0
F ₂	7.7	-0.9
H ₂	300	0.7
H ₂ S	5	8
HF	8	0
Methanol (CH ₃ OH)	960	<1
PH ₃	2	2
SO ₂	5	1

Performance data recorded at 20 – 25 °C, 30 - 50% RH, 900 - 1100 mbar

For further information about usage of Membrapor sensors, see application note [MEM1](#). The data contained in this document is for guidance only. Membrapor AG accepts no liability for any consequential losses, injury or damage resulting from the use of this document or from any omissions or errors herein. Customers should test under their own conditions to ensure that the sensors are suitable for their own requirements.



Silane Gas Sensor SiH₄/C-50

Temperature dependence

The output of an electrochemical sensor varies with temperature. The graphs below show the temperature-dependent variation of baseline and sensitivity, respectively. The results shown here are raw data (batch average) without any post-processing steps. The sensitivity and baseline are referenced to the signal at 20°C (reference point).

Please note: It is highly recommended to acquire the temperature dependence curves with the whole instrument. The sampling system, the humidity, the electronics and the interaction between the electronics and the sensor have a significant impact on the temperature dependence of the final measurement reading.

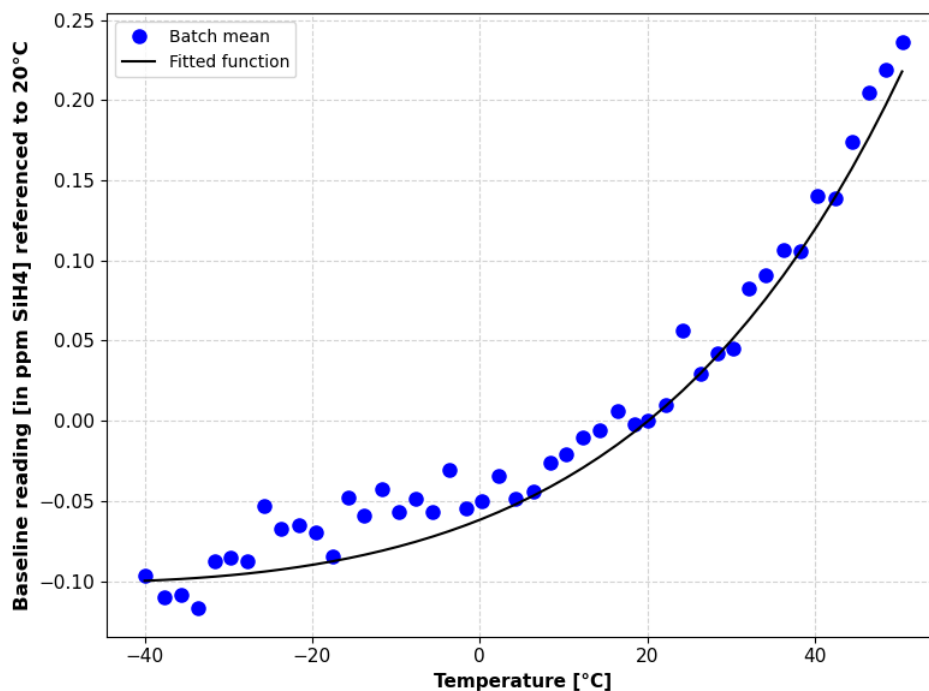

Baseline shifted with respect to reference point at 20°C.

Performance data recorded at 20 – 25 °C, 30 - 50% RH, 900 - 1100 mbar

For further information about usage of Memrapor sensors, see application note [MEM1](#). The data contained in this document is for guidance only. Memrapor AG accepts no liability for any consequential losses, injury or damage resulting from the use of this document or from any omissions or errors herein. Customers should test under their own conditions to ensure that the sensors are suitable for their own requirements.