



GPS/GLONASS/SBAS RECEIVER

NV08C-RTK-M L1/L2 GNSS Card

Datasheet

Version 1.1



NVS Technologies AG

Letzastrasse 2, 9462 Montlingen, Switzerland

Tel +41 71 760 07 36 Fax +41 71 760 07 38

www.nvs-gnss.com

Revision History

Revision ID	Date	Description
1.0	March, 2017	First Release of the document
1.1	November, 2017	General editing

Contents

Revision History	2
Contents	3
1 General Description.....	4
1.1. Introduction	4
1.2. Navigation Features	6
1.3. RF Functionalities.....	6
1.4. Environmental Data	7
2 Mechanical Specification.....	8
3 GNSS Antenna Interface.....	10
4 Data Interfaces and Protocols	10
4.1 Data interface	10
4.2 Data Protocol	11
4.3 Default Device Configuration.....	11
5 Electrical Specification	12
5.1 Absolute Maximum Ratings.....	12
5.2 DC Electrical Characteristics	12
5.3 AC Electrical Characteristics.....	13
5.4 System Connector Pin Assignment.....	14
5.5 Digital Signals Specification	14
5.5.1 RESET_IN Signal	14
5.5.2 UARTs and PPS Signals.....	15
5.5.3 1PPS Output.....	15
5.5.4 USB_N, USB_P Signals	15
6 Functional Description	16
6.1 Functional overview.....	16
6.2 GNSS Antenna Connection	16
6.3 Backup Power Supply VBAT	16
6.4 Firmware Update	16

1 General Description

1.1. Introduction

The NV08C-RTK-M GNSS Card is an easy-to-integrate GNSS module to provide advanced and high precision navigation functions to end user applications. The NV08C-RTK-M GNSS Card form-factor is compatible with NovAtel's OEM6, OEMStar, Superstar II, OEMV-1, OEMV-1G and OEMV1-DF receivers.

The NV08C-RTK-M GNSS Card provides 96 channels of combined GPS L1/L2, GLONASS L1/L2, Beidou B1/B2, GALILEO L1 and SBAS L1 code and carrier phase tracking. Position, velocity and time information is available at up to a maximum update rate of 10 Hz, with a 1 PPS (Pulse per Second) accuracy of 15 ns.

The NV08C-RTK-M GNSS Card uses Space Based Augmentation System (SBAS) corrections from services such as WAAS, EGNOS, MSAS and GAGAN.

The NV08C-RTK-M GNSS Card also provides processing of code and phase differential correction in RTCM format (version 3.1) to support DGNSS and RTK positioning modes.

The NV08C-RTK-M GNSS Card accepts a nominal input voltage between 3.3 and 5.0 VDC (minimum 3.0 to maximum 5.5 VDC) and uses NV08C NMEA command interfaces.

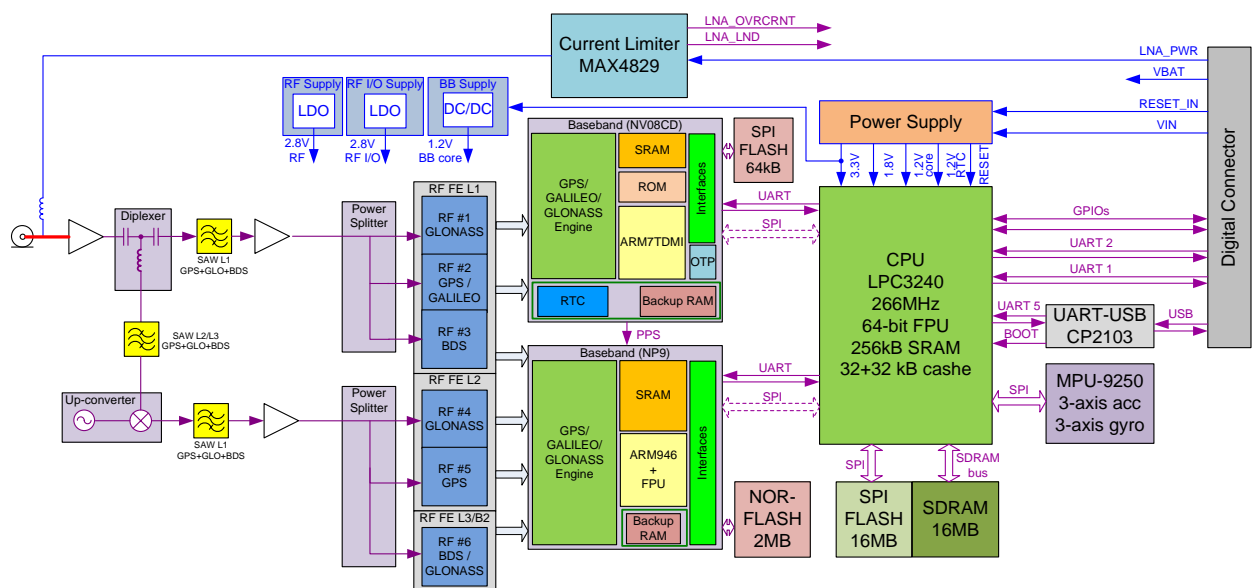

Figure 1. NV08C-RTK-M GNSS Card System Diagram

The NV08C-RTK-M GNSS Card is built on the NVS Technologies' compact NV08C high performance Global Navigation Satellite System (GNSS) receiver chipset. The NV08C's key feature is its compatibility with existing GNSS systems such as GPS and GLONASS and Satellite Based Augmentation Systems (SBAS), as well as with newly deployed GNSS systems.

The NV08C-RTK-M GNSS Card features a highly sensitive receiver to capture and maintain the satellite signals, combined with low power consumption, even when receiving multiple GNSS

and SBAS signals. Tracking satellites from multiple GNSS constellations ensures higher availability of navigation signals, when compared to single constellation alternatives, and provides increased performance, accuracy and reliability for devices used in urban and industrial environments. The NV08C-RTK-M module includes six separate RF paths (GPS L1/L2, GLONASS L1/L2 and Beidou B1/B2) and a 3-stage filtration for enhanced interference immunity.

The NV08C-RTK-M GNSS Card Features:

- L1 & L2 GPS, GLONASS, BeiDou (optional)
- Improved Dual Frequency RTK Engine
- Base and Rover mode
- On-board multipath mitigation
- Fast RTK acquisition and reacquisition
- Centimeter-level positioning in RTK mode
- 3-stage filtration for high out-of-band interference immunity
- Advanced Delta-Phase-Filter for pass-to-pass applications
- Low power consumption
- Simple quick integration
- NMEA 0183, RTCM 3.1 communication protocols
- Industrial operating temperature range -40 to +85°C
- Integrated MEMS-sensors (INS)

Please visit www.nvs-gnss.com for more information on NVS Technologies' NV08C GNSS Receiver Module Series.

Evaluations Tools:

An evaluation/development kit (NV08C-EVK-RTK-M) is available to help developers quickly familiarize themselves with the NV08C-RTK-M's features and functionalities. It is a flexible tool that allows users to evaluate the NV08C-RTK-M's various modes of operation, as well as to override default configurations/settings and interfaces.

The NV08C-EVK-RTK-M can be used with navigation systems to obtain current position (latitude, longitude and elevation), velocity and time, utilizing all available Global Navigation Satellite Systems (GNSS), including GPS, GLONASS and SBAS signals, at any location on earth and at any time.

1.2. Navigation Features

Parameter	Description
Supported GNSS signals	L1 GPS/SBAS C/A L2 GPS CM/CL L1 GLONASS CT L2 GLONASS CT B1 BeiDou (option) B2 BeiDou (option) L1 SBAS
Number of channels	96 channels
Time to first fix	Cold star: <40 s (25 s average) Warm start: < 35 s (25 s average) RTK initialization time (after 3D fix) < 10 s Initialization reliability 99.9%
Sensitivity	Cold star: – 143 dBm With A-GNSS: – 160 dBm Tracking mode: – 160 dBm RTK mode – 137 dBm
Accuracy ¹	Autonomous mode: < 1.5 m Differential mode SBAS: < 1 m Height: < 2 m RTK mode 1 cm + 1ppm Velocity: 0.05 m/s
1PPS time accuracy	15 ns accuracy (rms), 29.8 ns granularity (1/33.6 MHz)
Update rate	Up to 10Hz
Limitations	Velocity: less than 500 m/s Acceleration: less than 5 g Height: less than 50,000 m

¹ RMS, 24hr static, SV @ –137 dBm

1.3. RF Functionalities

The NV08C-RTK-M requires an active antenna to be connected to the RF input. Active antenna supply voltage is provided by Host System though ANT_PWR pin in digital connector.

The parameters of the NV08C-RTK-M's RF inputs are as shown in **Table 1**.

Table 1. RF Input Parameters

Active Antenna	
1dB Compression Point (P_{1dB})	+22.7 dBm
Input Return Loss	-16 dB
Total Noise Figure of the analogue path at the RF input	4 dB

Note – **Table 1** shows estimated values. The actual values may differ as a result of device qualification.

The output signals from GPS/GLONASS/BeiDou L1/L2 RF-SAW filters are further processed by six independent analogue ICs on six separate receiver channels:

- GPS/SBAS L1 (1575.42 MHz @ 8 MHz)
- GLONASS L1 (1602 MHz @ 8 MHz)
- GPS L2 (1227.6 MHz @ 8 MHz)
- GLONASS L2 (1246 MHz @ 8 MHz)
- BeiDou B1 (1561.098 MHz @ 8 MHz)
- BeiDou B2 (1207.14 MHz @ 8 MHz)

On all six channels the satellite signals are first down-converted to the IF band (at approximately 4 to 5 MHz), then filtered by Polyphase Filters with 8 MHz bandwidth. The signals then pass through a Variable Gain Amplifier with Automatic Gain Control. The analogue ICs include 2-bit ADCs that convert the signals from analogue to digital to be processed by the digital baseband IC. Typically all input channels are enabled to simultaneously receive all available navigation signals.

In order to facilitate fast acquisition of low level signals in poor reception areas, the NV08C-RTK-M contains a 33.6 MHz frequency generator (TCXO) with high temperature stability (± 0.5 ppm).

1.4. Environmental Data

Operating temperature: -40°C to $+85^{\circ}\text{C}$

Maximum relative humidity: 98% at $+40^{\circ}\text{C}$

2 Mechanical Specification

The overall dimension of the NV08C-RTK-M GNSS Card is 46x71 mm. The weight is approximately 30 g. Refer to Figure 2 and Figure 3 for the NV08C-RTK-M outline drawings with MCX and MMCX RF connector correspondingly.

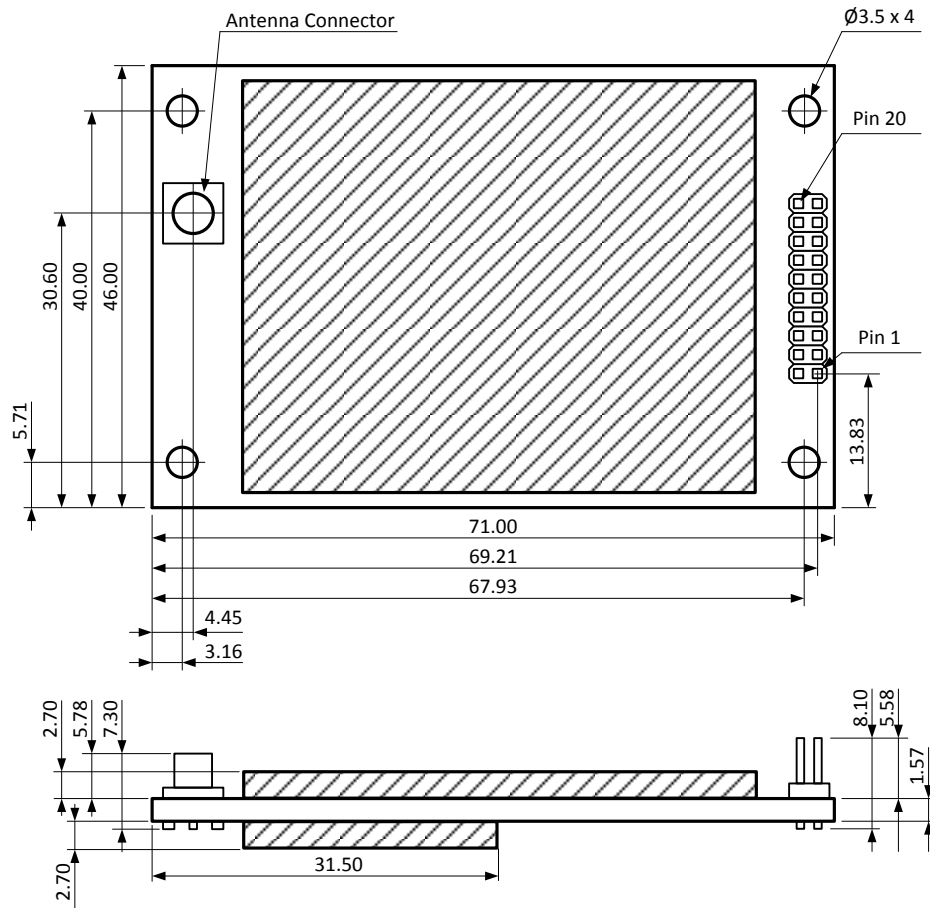

Note:

1. All dimensions are in mm
2. Dimensions are not for scale

Figure 2. Outline Drawing of NV08C-RTK-M GNSS Card with MCX connector

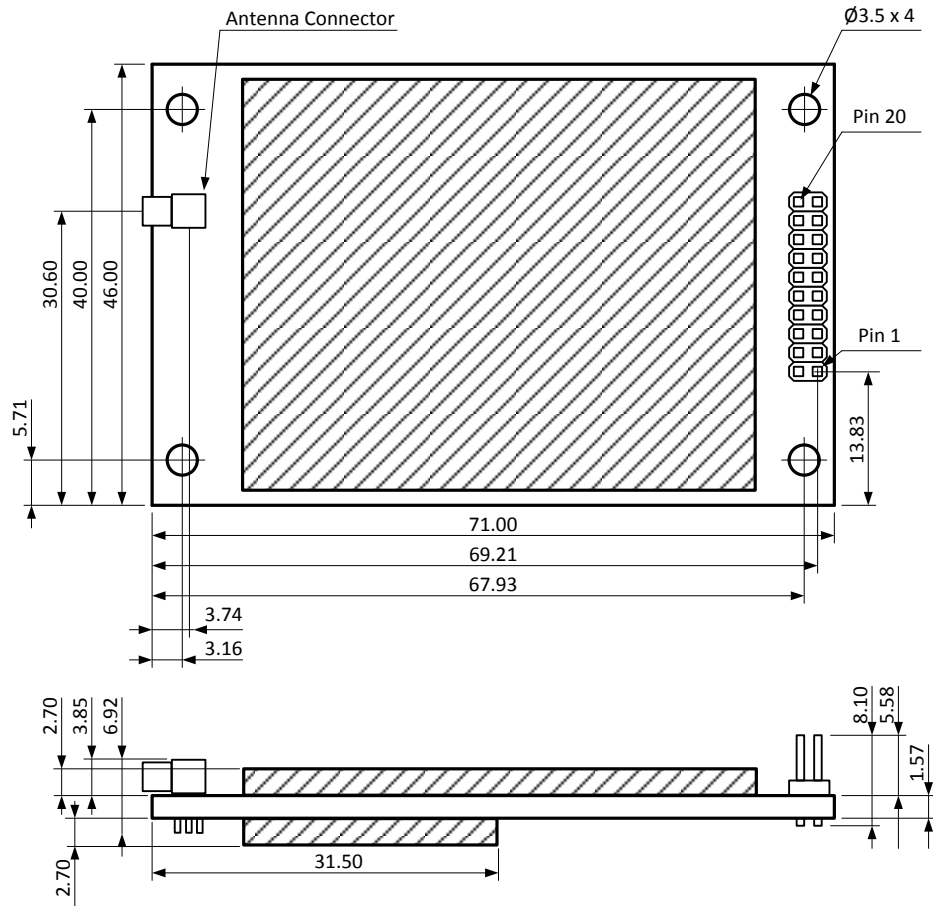

Note:

1. All dimensions are in mm
2. Dimensions are not for scale

Figure 3. Outline Drawing of NV08C-RTK-M GNSS Card with MMCX connector

3 GNSS Antenna Interface

The NV08C-RTK-M GNSS Card uses MMCX Right Angle Jack (R1.1 modification) or MCX Straight Jack (R1.2 modification) for active antenna connection.

Active antenna supply voltage is provided by Host System through ANT_PWR pin in digital connector.



Figure 4. Active GNSS Antenna Input (MMCX connector)

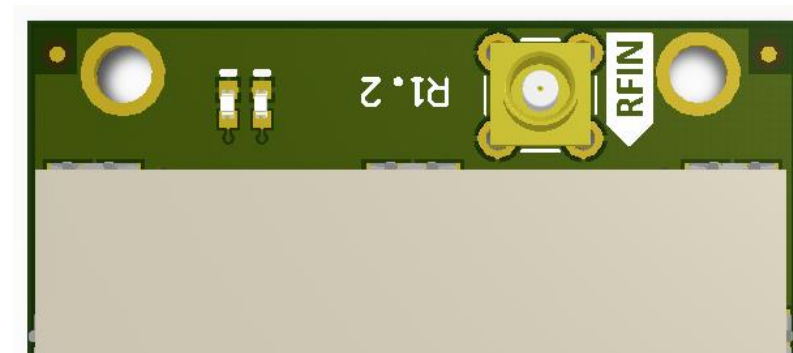

Figure 5. Active GNSS Antenna Input (MCX connector)

4 Data Interfaces and Protocols

4.1 Data interface

The NV08C-RTK-M GNSS Card features 20 (2x10) pin Header 2.0 mm Pitch (male) for connection to a Host System. For communication with the Host System two UART and one USB interfaces are available on the module. Drivers for USB interface are to be supplied with the module.

Supported baud rate for communication with NV08C-RTK-M GNSS Card is 4800 to 460800 bps.

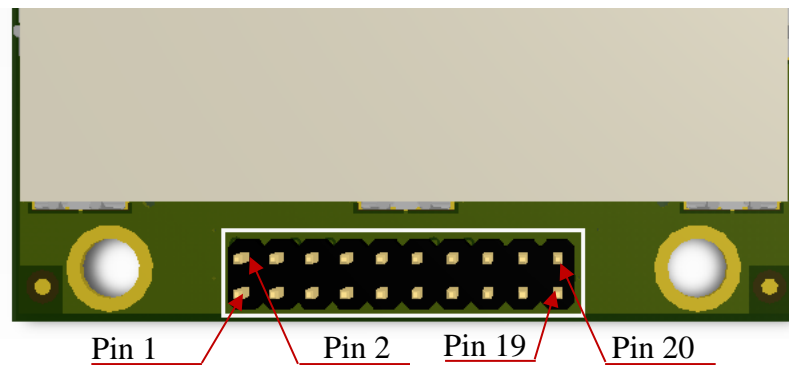

Figure 6. System connector

4.2 Data Protocol

The NV08C-RTK-M's supported protocols are as follows:

- NMEA 0183 v2.3 (IEC61162-1)
- RTCM v.3.0, v3.1
- BINR (proprietary binary protocol is available if requested)

Data update/output rate: 1, 2, 5, 10, 20* Hz

* - 20 Hz position/velocity output rate is supported with GNSS+INS mode

4.3 Default Device Configuration

By default, the NV08C-RTK-M's interfaces are preconfigured to support the following communication protocols:

- UART 1: NMEA, 115200 bps (messages/rates: GGA/1, RMC/1, GSV/1, GSA/1)
- UART 2: RTCM v3.x, 115200 bps communication
- USB: NMEA, 230400 bps (messages/rates: GGA/1, RMC/1, GSV/1, GSA/1).

Refer to NV08C-RTK-M Receivers Protocol Specification for further details.

For communication with NMEA and RTCM protocol UART ports should to be configured as 1 start – 8 data - 1 stop bit.

Other NV08C-RTK-M GNSS Card default settings:

- Navigation mode: RTK Rover, GPS and GLONASS L1 & L2
- RTCM data: accounted automatically (RTK modes)
- SBAS data: on demand (\$PNVGNV NMEA command)
- RAIM: automatic
- Navigation data update rate: 5 Hz
- NMEA messages: see the Protocol Specification document

5 Electrical Specification

5.1 Absolute Maximum Ratings

Table 2 provides the NV08C-RTK-M's absolute maximum (stress) ratings. Operation at or beyond these maximum ratings might cause permanent damage to the device.

Table 2. Absolute Maximum Ratings

Parameter	Minimum	Maximum	Unit
Operating Temperature Range	-40	+85	°C
Relative humidity @ 40°C		98	%
Supply Voltage	-0.3	+5.5	V
External Active Antenna Supply Voltage	-0.3	+6	V
RF Input Power		5	dBm

5.2 DC Electrical Characteristics

Table 3. DC Electrical Characteristics

Parameter	Minimum	Typical	Maximum	Unit
Supply Voltage	3.0	3.3	5.0	V
Supply current ¹		260 ¹	350	mA
Power consumption ¹		900	1200	mW
Active Antenna DC Bias				
Voltage	2.3	-	5.5	V
Current	10 ²	100	240 ³	mA

¹ Excluding active antenna current consumption

² Minimum threshold of active antenna current detector

³ Maximum supplied active antenna current

5.3 AC Electrical Characteristics

Table 4. AC Electrical Characteristics

Parameter	Typical	Unit
RF Chains		
L1 GPS/GALILEO/SBAS Centre Frequency	1575.42	MHz
L1 GPS/GALILEO/SBAS Bandwidth	8	MHz
L1 GLONASS Centre Frequency	1602	MHz
L1 GLONASS Bandwidth	8	MHz
L2 GPS/GALILEO/SBAS Centre Frequency	1227.6	MHz
L2 GPS/GALILEO/SBAS Bandwidth	8	MHz
L2 GLONASS Centre Frequency	1246	MHz
L2 GLONASS Bandwidth	8	MHz
Active antenna input		
Input P1dB	+4	dBm
Noise Figure	4	dB
Impedance	50	Ω
Return Loss	-16	dB

5.4 System Connector Pin Assignment

Table 5. System Connector Pin Assignment

Pin#	Name	Description	Pin#	Name	Description
1	ANT_PWR	External active antenna supply	2	VIN	Device's supply
3	USB_N	USB data "minus"	4	USB_P	USB data "plus"
5	RESET_IN	Device RESET input	6	Reserved	
7	VBAT	Backup battery supply	8	NC	Not Connected
9	EVENT	EVENT input	10	GND	Ground
11	UART1 TX	UART1 transmitter output	12	UART1 RX	UART1 receiver input
13	GND	Ground	14	UART2 TX	UART2 transmitter output
15	UART2 RX	UART2 receiver input	16	GND	Ground
17	Reserved		18	GND	Ground
19	PPS	Pulse per second output	20	NC	Not Connected

5.5 Digital Signals Specification

5.5.1 RESET_IN Signal

The RESET_IN signal can be used for NV08C-RTK-M Card reset.

The NV08C-RTK-M Card has Power Supervisor inside. Therefore Host System does not need to specially control this signal during the NV08C-RTK-M Card power up. The NV08C-RTK-M Card is in active mode when RESET_IN signal is de-asserted.

To provide forced reset of the NV08C-RTK-M Card the Host System should provide a pulse to the RESET_IN input as specified below:

- Voltage level – less than 0.7 V
- The pulse length – no less than 1 ms

After the signal is applied (RESET_IN signal level goes from low to high) the integrated power supervisor holds the NV08C-RTK-M Card in reset mode for at least 140 ms.

Table 6. RESET_IN signal level requirements

Parameter	Minimum	Typical	Maximum	Unit
High Level Input Voltage	2.1	3.3	3.6	V
Low Level Input Voltage	-0.3	0	0.7	V

5.5.2 UARTs and PPS Signals

The NV08C-RTK-M Card has 3.3V nominal voltage for UARTs and PPS I/O signals

Table 7. Input Voltage for UART1, UART2, PPS

Symbol	Parameter	IO Supply Voltage	Minimum	Typical	Maximum	Unit
V _{IH}	High Level Input Voltage	3.3V	2.0	3.3	3.6	V
V _{IL}	Low Level Input Voltage	3.3V	-0.3	0	0.8	V

5.5.3 1PPS Output

1PPS output is present at the Pin#19. By default 1PPS signal is generated permanently and independently of a valid position fix whether available or not. If a valid position fix is not available, the 1PPS signal will be generated each second as per the internal hardware's defined time scale. If a valid position fix is available, the 1PPS signal refers to a user defined time standard (UTC by default). If required the 1PPS output can be set to operate only when a valid position fix is available.

1PPS signal parameters:

- Voltage level 3.3V (CMOS)
- Output frequency 1 Hz
- True time Refer to the pulse rising (default) or the falling edge
- Pulse duration 29.8 ns to 1.95 ms (1 ms by default)
- Refers to UTC (default), GPS, GLONASS or UTC SU time standard
- 1PPS accuracy ±15 ns (antenna cable delay to be compensated)
- 1PPS granularity 29.8 ns (33.6 MHz TCXO referenced)

The rising (or falling) edge shift is relative to the defined time-standard, and is available in the NMEA \$PNVGUTC command.

5.5.4 USB_N, USB_P Signals

USB_N, USB_P signals provides USB serial data interface for communication with Host System. USB serial data interface is compliant to the USB 2.0 full-speed device specification.

6 Functional Description

6.1 Functional overview

The NV08C-RTK-M GNSS Card with a connected external antenna provides automatic acquisition, tracking and positioning of GNSS signals. Navigation data is provided to the Host System by means of NMEA protocol.

6.2 GNSS Antenna Connection

The NV08C-RTK-M GNSS Card uses MMCX Right Angle Jack (R1.1 modification) or MCX Straight Jack (R1.2 modification) for active antenna connection. The active antenna supply voltage should be provided by Host System through ANT_PWR pin (pin#1 in digital connector). The active GNSS antenna input includes an auto-detection feature with short-circuit protection. The supply current is limited to 100 mA typ. (240 mA max.) in case of short-circuit on the active antenna connector.

It is very important to select a proper antenna to achieve optimum performance.

If an active antenna is employed, excessive LNA gain and bandwidth may reduce the quality of signal reception, due to potential in-band and out-of-band interferences. As well, an active antenna with insufficient gain or bandwidth, or high cable loss may decrease the receiver's sensitivity.

Recommended active antenna parameters are as follows:

- GPS/GLONASS L1 & L2
- Gain including LNA and cable losses 20 to 30 dB
- Built-in LNA noise figure <2 dB
- RF Output Impedance 50 Ω
- Return Loss <-10 dB
- Out-of-band signal Rejection: at least 35dB @ $f_c \pm 70$ MHz.

6.3 Backup Power Supply VBAT

If an independent VBAT voltage is applied, the NV08C-RTK-M module can store (in its BRAM) navigation parameters (almanac, ephemeris, last calculated coordinates etc.).

When navigation parameters are stored, the module is able to provide warm or hot starts (depending on its switch-off time and available navigation data).

If no VBAT voltage is applied to the module, all data saved in the BRAM will be erased when the module is powered off.

6.4 Firmware Update

The NV08C-RTK-M GNSS Card's Firmware can be updated. The PatchWriter (a software tool to download Firmware) and the latest revision of the FW are to be provided by NVS' support team.

The Host System can also download new FW to the NV08C-RTK-M GNSS Card by means of NMEA command: `$PNVGPRL,C*2E\r\n`.

Once NV08C-RTK-M receives the command it switches over to the programming mode and starts transmitting of "0x43" character (in ASCII format – character "C"). In response the Host System should download a new FW as a sequence of bytes (FW binary file) by means of the X-modem-CRC protocol. Once the binary file has been completely downloaded, the NV08C-RTK-M stores the new loaded FW into embedded non-volatile memory and then forces restart of the device.

NVS Technologies can support application specific requirements. Contact NVS' Support Team for customization of standard functionality.

Caution – *The process of storing the FW to FLASH memory will only begin when transmission of the Patch to the module has been fully completed. (This will require a few seconds depending on the data transferring baud rate). During this process the NV08C-RTK-M GNSS Card must not be powered-off and RESET signal must not be applied. Turning off or resetting the device while downloading a FW might lead to a malfunction of the NV08C-RTK-M GNSS Card and recovery can only be done by the factory.*