

# VSM6328

## VSM6328 Mini Embedded VeroStar™ Triple-band GNSS Precision Antenna

Frequency Coverage: GPS/QZSS-L1/L2/L5, GLONASS-G1/G2/G3, Galileo-E1/E5a/E5b, BeiDou-B1/B2/B2a, NavIC-L5

The patent-pending VSM6328 antenna employs Tallysman's unique VeroStar™ technology, providing high gain over the GPS/QZSS-L1/L2/L5, GLONASS-G1/G2/G3, Galileo-E1/E5a/E5b, BeiDou-B1/B2/B2a, and NavIC-L5 frequency bands, including the satellite-based augmentation system (SBAS) available in the region of operation [WAAS (North America), EGNOS (Europe), MSAS (Japan), or GAGAN (India)].

The light and compact embedded VeroStar™ VSM6328 is designed and crafted for high-accuracy positioning while being robust and reliable.

With an exceptionally low roll-off from zenith to the horizon, the VeroStar™ antenna provides the best-in-class tracking of GNSS signals from low elevation angles. In addition, the optimized axial ratio at all elevation angles results in excellent multipath rejection, thus enabling accurate and precise code and phase tracking of GNSS signals.

A wide-band spherical antenna element enables the VeroStar™ to deliver a  $\pm 2$  mm phase centre variation (PCV), making it ideal for high-precision applications, such as autonomous vehicle navigation (land, sea, and air), smart survey devices, and maritime positioning.

The VeroStar™ antenna features a robust pre-filter and high-IP3 LNA architecture, minimizing de-sensing from high-level out-of-band signals, including 700 MHz LTE, while still providing a noise figure of only 1.8 dB.

The embedded VeroStar™ antenna has passed shock and vibration tests to ensure it can survive the rigours of day-to-day field use.

The unique features of the VeroStar™ antenna guarantee it can deliver high signal-to-noise ratio (SNR) and highly accurate and precise code and phase tracking of GNSS signals from all elevation angles in the most challenging environments.



90 mm ground plane shown

### Applications

- High-precision GNSS systems
- All embedded precision applications, such as:
  - Autonomous vehicle navigation (land, sea, air)
  - Deformation monitoring stations
  - Land survey rover
  - Marine navigation
  - RTK/PPP systems
  - Reference networks

### Features

- Tight phase centre variation ( $\pm 2$  mm typ.)
- Low axial ratios from zenith to horizon
- Low roll-off from zenith to the horizon
- High G/T at low elevation angles
- Invariant performance from 3.0 to 16 VDC
- Low current (50 mA)
- Low noise figure (1.8 dB)
- Light, compact, and robust design
- REACH, and RoHS compliant

### Benefits

- Consistent performance across all frequency bands
- Excellent GNSS tracking from low elevation angles
- Extreme accuracy and precision
- Excellent multipath rejection

**About Tallysman:** With global headquarters and manufacturing in Ottawa, Canada, Tallysman is a leading manufacturer of high-precision antennas and components for Global Navigation Satellite System (GNSS) applications. Tallysman's mission is to support the needs of a new generation of positioning systems by delivering unprecedented antenna precision at competitive prices. Learn more at [www.tallysman.com](http://www.tallysman.com)

Revision: 1.0

**Contact us:**  
[info@tallysman.com](mailto:info@tallysman.com)  
T: +1 613 591-3131

# VSM6328 Mini Embedded VeroStar™ Triple-band GNSS Precision Antenna

Frequency Coverage: GPS/QZSS-L1/L2/L5, GLONASS-G1/G2/G3, Galileo-E1/E5a/E5b, BeiDou-B1/B2/B2a, NavIC-L5

## Antenna

Technology: GNSS triple-band crossed dipoles

GNSS		Gain		Axial Ratio
		dBic typ. at Zenith		dB at Zenith
		90 mm	106 mm	
GPS / QZSS	L1	3.5	4.0	< 1.0
	L2	4.0	4.5	< 1.0
	L5	3.5	4.0	< 1.0
GLONASS	G1	3.5	4.0	< 1.0
	G2	4.0	4.5	< 1.0
	G3	4.0	4.5	< 1.0
Galileo	E1	3.5	4.0	< 1.0
	E5a	3.5	4.0	< 1.0
	E5b	4.0	4.5	< 1.0
	E6	-	-	-
BeiDou	B1	3.5	4.0	< 1.0
	B2	4.0	4.5	< 1.0
	B2a	3.5	4.0	< 1.0
	B3	-	-	< 1.0
IRNSS / NavIC	L5	3.5	4.0	< 1.0
QZSS	L6	-	-	-
L-band correction services		-	-	-
Satellite Communications				
Iridium		-	-	-
Globalstar		-	-	-
Other				
Axial Ratio at 10°	5.0 dB max.	Efficiency		> 70%
Phase Centre Variation	± 2 mm typ. (no azi.)	G/T @10°C (GPS/QZSS-L1)		≥ -25.4 dB/K

## Mechanicals

Mechanical Size	90 mm or 106 mm (dia.) x 32.4 mm (h.)
Weight	58g (90 mm)   69 g (106 mm)
Available Connectors	MCX female
Radome / Enclosure	-
Mount	8x M2 screws

## Environmental

Operating Temperature	-45 °C to +85 °C
Storage Temperature	-55 °C to +95 °C
Mechanical Vibration	MIL-STD-810E - Test method 514.5
Shock and Drop	MIL-STD-810G - Test method 516.6
Salt Fog	-
Low Pressure - Altitude	-
IP Rating (housing)	-
Compliance	IPC-A-610, FCC Part 15, RED / CE Mark, RoHS, REACH

## Warranty:

Parts and Labour	1-year standard warranty
------------------	--------------------------

## Low Noise Amplifier (LNA) - Measured at 3.0 VDC and 25°C

Frequency Bandwidth	Out-of-Band Rejection
Lower Band 1160 - 1255 MHz	≥ 75 dB @ ≤ 500 MHz ≥ 60 dB @ ≤ 900 MHz ≥ 52 dB @ ≤ 1120 MHz ≥ 16 dB @ ≥ 1290 MHz ≥ 42 dB @ ≥ 1310 MHz ≥ 55 dB @ ≥ 1350 MHz ≥ 75 dB @ ≥ 1390 MHz
Upper Band 1559 - 1606 MHz	≥ 70 dB @ ≤ 1450 MHz ≥ 54 dB @ ≤ 1525 MHz ≥ 51 dB @ ≤ 1532 MHz ≥ 41 dB @ ≤ 1540 MHz ≥ 27 dB @ ≥ 1626 MHz ≥ 65 dB @ ≥ 1700 MHz

Architecture	Pre-filter → LNA stage 1 → filter → LNA stage 2
Gain	28 dB min.
Noise Figure	1.8 dB typ. @ 25 °C
VSWR	< 1.5:1 typ.   1.8:1 max.
Supply Voltage Range	3.0 to 16 VDC nominal
Supply Current	50 mA typ.
ESD Circuit Protection	15 kV air discharge
P 1dB Output	+ 6.0 dBm
Group Delay Variation	< 10 ns

## Mechanical Diagram

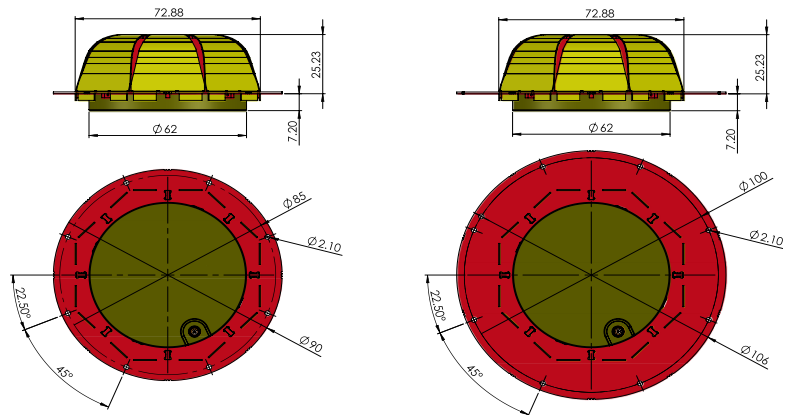

\*Two ground plane diameters are available: 90 mm and 106 mm.

## Ordering Information

Part Number: **33-VSM6328-xxx**

where xxx = ground plane diameter: 090 = 90 mm | 106 = 106 mm

Please refer to our **Ordering Guide** to review available radomes and connectors at: <https://www.tallysman.com/resource/tallysman-ordering-guide/>